



Racing

MOTORSPORT EQUIPMENT



10th Edition



CONTENTS

PIT EQUIPMENT

Stainless Steel Wheel and Tyre Trolley	5 - 6
Powder Coated Wheel and Tyre Trolley	7
Folding Wheel and Tyre Trolley	8
Single Tier Wheel and Tyre Trolley	9
Folding Pit Trolley	10
Wheel and Tyre Dolly	11
Folding Utility Work Station	12
Folding Mobile Work Stand & Lightweight Tool Tray	13
Large Folding Table	14
Folding Wall Mounted Table	15
Folding Paddock Table	16
Wheel and Tyre Cleaning Bath	17
Single Air/Gas Bottle Trolley	18
Battery Trolleys	19
Fuel Bottle Stands - Premier & ATL Bottle	20 - 21
Quick Lift Jacks	22 - 23
Formula Rear Swivel Jack	24
Wide Body Quick Lift Jack	25
Sill Stands & Chassis Stands	26 - 27
Vehicle Ramps	28 - 29
Standard Pit Boards, Numbers, Bags & Kits	30 - 31
Large Pit Boards, Numbers, Bags & Kits	32 - 33
Pit Stop Lollipop	34
Mechanics Work Mats	35
Hand Wash Stations & Fluid Cabinets	36 - 37
Shelves, Cabinets & Fluid Spill Trays	38 - 39

SET UP EQUIPMENT

3" Clubman & Wireless Race Scales	40 - 41
Modular Scale Pad Levelling Trays	42
Modular Scale Pad Roll Off Platforms	43
Levelling Tray Leg Extension Kits	44
Aluminium Scale Pad Levelling Trays	45
Hub Stands, Pro Sticks & Accessories	46 - 49
Digital Dual Axis Angle Gauge	50
Billet Digital Camber / Castor Gauge with Magnetic Adaptor	51
Billet Bubble Camber / Castor Gauge with Magnetic Adaptor	52
Aluminium Camber Frame	53
Aluminium Toe Measuring Plates	54
Laser Levelling Kit	55
Turn Plates	56
EZ Sweep Castor Slip Plates	57
String Lines Kit	58 - 59
Bump Steer Gauge	60
Tyre Pressure Gauge	61
Infrared Thermometer Gun	62

VEHICLE EQUIPMENT

Steering Wheel Quick Releases	63
Steering Wheel Spacers/Adaptors & Hub Kits	64 - 65
Wide Angle Rear View Mirrors	66 - 67

ACCESSORIES

Tools & Accessories	68 - 70
---------------------	---------

LEGENDS



T: +44 (0) 1268 764411
 E: sales@bg-racing.co.uk
 W: www.bg-racing.co.uk



STAINLESS STEEL WHEEL AND TYRE TROLLEY

Chariot à pneus en acier inoxydable
 Reifenwagen edelstahl
 Carrello pneumatici acciaio inox
 Carro para el transporte de ruedas

An extremely high quality and versatile Wheel and Tyre Trolley featuring adjustable internal beam widths of 400mm, 475mm and 550mm to cater for various diameter wheels and tyres. Available in either 1300mm, 1500mm, 1600mm or 1800mm demountable tyre friendly round cross beam lengths.

Two fixed and two fully-rotating locking and braking aluminium castor wheels are supplied as standard to give strength, stability and easy manoeuvrability around the pits, paddock and workshop.

Manufactured from high quality 304 grade stainless steel with a superb hand-polished mirror finish.

Supplied with an A-frame with M12 rod end for connecting to a paddock vehicle (maximum towing speed of 5mph/8kph).

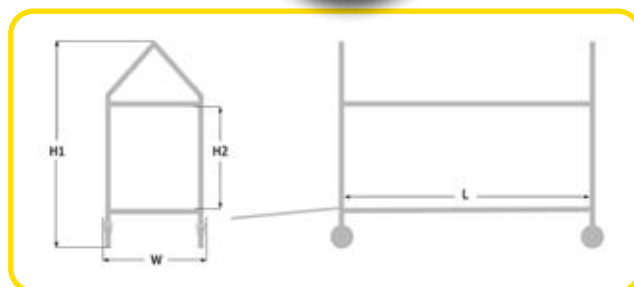

TECHNICAL SPECIFICATIONS

PART NUMBER	BGR103S	BGR104S	BGR115S	BGR102S
MATERIAL	STAINLESS STEEL	STAINLESS STEEL	STAINLESS STEEL	STAINLESS STEEL
FINISH	HAND POLISHED	HAND POLISHED	HAND POLISHED	HAND POLISHED
HEIGHT (H1)	1580mm – 62.20"	1580mm – 62.20"	1580mm – 62.20"	1580mm – 62.20"
WIDTH (W)	725mm – 28.54"	725mm – 28.54"	725mm – 28.54"	725mm – 28.54"
INTERNAL LENGTH (L)	1300mm – 51.18"	1500mm – 59.05"	1600mm – 62.99"	1800mm – 70.86"
INTERNAL WIDTHS	400mm – 15.74" 475mm – 18.70"	400mm – 15.74" 475mm – 18.70"	400mm – 15.74" 475mm – 18.70"	400mm – 15.74" 475mm – 18.70"
INTERNAL HEIGHT (H2)	550mm – 21.65" 721mm – 28.38"	550mm – 21.65" 721mm – 28.38"	550mm – 21.65" 721mm – 28.38"	550mm – 21.65" 721mm – 28.38"
NETT WEIGHT	51.80kg – 114.20lb	53.70kg – 118.39lb	55.40kg – 122.14lb	58.80kg – 129.63lb
LOADING CAPACITY	300kg (150kg PER LEVEL) 660lb (330lb PER LEVEL)	300kg (150kg PER LEVEL) 660lb (330lb PER LEVEL)	300kg (150kg PER LEVEL) 660lb (330lb PER LEVEL)	300kg (150kg PER LEVEL) 660lb (330lb PER LEVEL)
WHEEL DIAMETER	160mm – 6.29"	160mm – 6.29"	160mm – 6.29"	160mm – 6.29"
WHEEL MATERIAL	ALUMINIUM	ALUMINIUM	ALUMINIUM	ALUMINIUM
TYRE MATERIAL	RUBBER	RUBBER	RUBBER	RUBBER



T: +44 (0) 1268 764411
 E: sales@bg-racing.co.uk
 W: www.bg-racing.co.uk





STAINLESS STEEL LOW LEVEL WHEEL AND TYRE TROLLEY

Chariot à pneus en acier inoxydable
Reifenwagen edelstahl
Carrello pneumatici acciaio inox
Carro para el transporte de ruedas



CUSTOM
SIZES
AVAILABLE
UPON
REQUEST

An extremely high quality Wheel and Tyre Trolley designed to be suitable for trucks which are limited on available space with an overall height of only 1385mm and fixed internal beam width of 475mm. Available in either 1300mm, 1500mm, 1600mm or 1800mm demountable tyre friendly round cross beam lengths.

Two fixed and two fully-rotating locking and braking castor wheels are supplied as standard to give strength, stability and easy manoeuvrability around the pits, paddock and workshop.

Manufactured from high quality 304 grade stainless steel with a superb hand-polished mirror finish.

Supplied with an A-frame with M12 rod end for connecting to a paddock vehicle (maximum towing speed of 5mph/8kph).

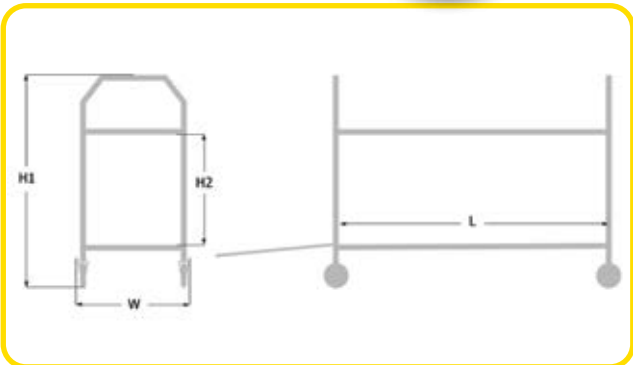

TECHNICAL SPECIFICATIONS

PART NUMBER	BGR103SL	BGR104SL	BGR115SL	BGR102SL
MATERIAL	STAINLESS STEEL	STAINLESS STEEL	STAINLESS STEEL	STAINLESS STEEL
FINISH	HAND POLISHED	HAND POLISHED	HAND POLISHED	HAND POLISHED
HEIGHT (H1)	1385mm - 54.52"	1385mm - 54.52"	1385mm - 54.52"	1385mm - 54.52"
WIDTH (W)	700mm - 27.55"	700mm - 27.55"	700mm - 27.55"	700mm - 27.55"
INTERNAL LENGTH (L)	1300mm - 51.18"	1500mm - 59.05"	1600mm - 62.99"	1800mm - 70.86"
INTERNAL WIDTH	475mm - 18.70"	475mm - 18.70"	475mm - 18.70"	475mm - 18.70"
INTERNAL HEIGHT (H2)	721mm - 28.38"	721mm - 28.38"	721mm - 28.38"	721mm - 28.38"
NETT WEIGHT	49.40kg - 108.91lb	51.30kg - 113.10lb	53.00kg - 116.84lb	56.40kg - 124.34lb
LOADING CAPACITY	300kg (150kg PER LEVEL)	300kg (150kg PER LEVEL)	300kg (150kg PER LEVEL)	300kg (150kg PER LEVEL)
	660lb (330lb PER LEVEL)	660lb (330lb PER LEVEL)	660lb (330lb PER LEVEL)	660lb (330lb PER LEVEL)
WHEEL DIAMETER	160mm - 6.29"	160mm - 6.29"	160mm - 6.29"	160mm - 6.29"
WHEEL MATERIAL	ALUMINIUM	ALUMINIUM	ALUMINIUM	ALUMINIUM
TYRE MATERIAL	RUBBER	RUBBER	RUBBER	RUBBER



T: +44 (0) 1268 764411
E: sales@bg-racing.co.uk
W: www.bg-racing.co.uk

POWDER COATED WHEEL AND TYRE TROLLEY

Chariot à pneus en acier
 Reifenwagen pulverbeschichtet
 Carrello pneumatici
 Carro para el transporte de ruedas

Convenience and quality come together in the design and manufacture of this sturdy Powder Coated Wheel and Tyre Trolley, equally practical for transport in the pit and paddock, or for storage back at the workshop.

Demountable tyre friendly round cross beams reduce the marking of tyres and are available in 1300mm, 1500mm or 1600mm internal lengths. The height of the top beams can also be adjusted in 3 positions depending on the diameter of your tyres and to reduce the overall trolley height when in use.

Two fixed and two fully-rotating locking and braking castor wheels are designed for strength and ease of movement around the pits, paddock and workshop.

Manufactured from high-grade mild steel with a durable silver grey powder coated finish.

Two optional A-Frames fitted with an M12 Rod End and a Rear Towing Frame are available separately (maximum towing speed of 5mph/8kph). It is recommended that Aluminium Wheels (BGR113P / BGR114P / BGR124P) are used for towing.



TECHNICAL SPECIFICATIONS

PART NUMBER (PP WHEELS)	BGR110P	BGR111P	BGR123P
PART NUMBER (ALI WHEELS)	BGR113P	BGR114P	BGR124P
MATERIAL	MILD STEEL	MILD STEEL	MILD STEEL
FINISH	POWDER COATED	POWDER COATED	POWDER COATED
HEIGHT (H1)	1300mm – 51.18"	1300mm – 51.18"	1300mm – 51.18"
WIDTH (W)	600mm – 23.62"	600mm – 23.62"	600mm – 23.62"
INTERNAL LENGTH (L)	1300mm – 51.18"	1500mm – 59.05"	1600mm – 62.99"
INTERNAL WIDTH	450mm – 17.71"	450mm – 17.71"	450mm – 17.71"
INTERNAL HEIGHTS (H2)	623.5mm – 24.54"	623.5mm – 24.54"	623.5mm – 24.54"
	673.5mm – 26.51"	673.5mm – 26.51"	673.5mm – 26.51"
	723.5mm – 28.48"	723.5mm – 28.48"	723.5mm – 28.48"
NETT WEIGHT	34.40kg – 75.84lb	36.30kg – 80.03lb	39.60kg – 87.12lb
LOADING CAPACITY	300kg (150kg PER LEVEL)	300kg (150kg PER LEVEL)	300kg (150kg PER LEVEL)
	660lb (330lb PER LEVEL)	660lb (330lb PER LEVEL)	660lb (330lb PER LEVEL)
WHEEL DIAMETER	160mm – 6.29"	160mm – 6.29"	160mm – 6.29"
WHEEL MATERIAL	PP OR ALUMINIUM	PP OR ALUMINIUM	PP OR ALUMINIUM
TYRE MATERIAL	RUBBER	RUBBER	RUBBER

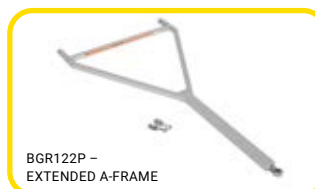
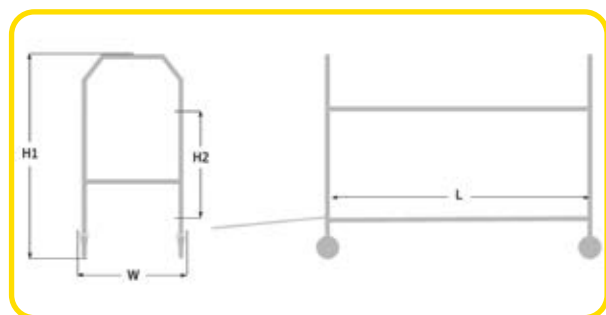

OPTIONS	STD A-FRAME	EXT A-FRAME	REAR TOWING FRAME	ALI WHEEL SET
PART NUMBER	BGR112P	BGR122P	BGR112PR	BGR120
MATERIAL	MILD STEEL	MILD STEEL	MILD STEEL	ALI/RUBBER
FINISH	POWDER COATED	POWDER COATED	POWDER COATED	N/A
HEIGHT	19mm – 0.75"	19mm – 0.75"	70mm – 2.75"	N/A
WIDTH	505mm – 19.88"	505mm – 19.88"	40mm – 1.57"	N/A
LENGTH	590mm – 23.22"	970mm – 38.18"	450mm – 17.71"	N/A
NETT WEIGHT	1.30kg – 2.87lb	1.80kg – 3.97lb	800g – 1.76lb	8.08kg – 17.81lb



T: +44 (0) 1268 764411
 E: sales@bg-racing.co.uk
 W: www.bg-racing.co.uk



FOLDING WHEEL AND TYRE TROLLEY

Chariot à pneus en pliable
 Klappbarer Reifenwagen
 Carrello pieghevole
 porta pneumatici
 Carro plegable para el
 transporte de ruedas



ITEMS SHOWN ON TROLLEY NOT INCLUDED

Fully assembled, the trolley can carry multiple wheels and tyres on the tyre friendly round cross beams as well as tools, parts and other accessories in the bottom tray. The tray has also been specifically designed to accommodate stackable Euro Bins allowing users to maximise the storage space available.

When not in use, simply remove the beams and secure them in the empty tray before folding flat each end frame and locking them shut. The trolley can then be slid in to any suitable space for storage and transportation.

Two fixed and two fully-rotating locking & braking castor wheels are provided for strength and ease of movement around the pits, paddock and workshop.

An optional A-Frame fitted with an M12 Rod End, and a Rear Towing Frame are available separately (Maximum towing speed of 5mph/8kph). It is recommended that Aluminium Wheels (BGR108PAL) are used for towing.

Manufactured from high-grade mild steel with a durable silver grey powder coated finish.



TECHNICAL SPECIFICATIONS

PART NUMBER (PP WHEELS)	BGR108P
PART NUMBER (ALU WHEELS)	BGR108PAL
MATERIAL	MILD STEEL
FINISH	POWDER COATED
HEIGHT (H1)	940mm - 37.00"
WIDTH (W1)	580mm - 22.83"
INTERNAL LENGTH (L)	1195mm - 47.05"
INTERNAL WIDTH (W2)	430mm - 16.93"
INTERNAL HEIGHT (H2)	635mm - 24.54"
FOLDED HEIGHT	145mm - 5.71"
FOLDED WIDTH	580mm - 22.84"
FOLDED LENGTH	1890mm - 74.41"
NETT WEIGHT	35.00kg - 77.16lb
LOADING CAPACITY	300kg (150kg PER LEVEL)
	660lb (330lb PER LEVEL)
WHEEL DIAMETER	160mm - 6.29"
WHEEL MATERIAL	PP OR ALUMINIUM
TYRE MATERIAL	RUBBER

OPTIONS	A-FRAME	REAR TOWING FRAME	EURO BIN	EURO BIN
PART NUMBER	BGR108PAF	BGR108PRT	BGR275EB	BGR276EB
MATERIAL	MILD STEEL	MILD STEEL	PLASTIC	PLASTIC
HEIGHT	19mm - 0.75"	70mm - 2.75"	120mm - 4.72"	120mm - 4.72"
WIDTH	505mm - 19.88"	40mm - 1.57"	400mm - 15.74"	300mm - 11.81"
LENGTH	590mm - 23.22"	450mm - 17.71"	600mm - 23.62"	400mm - 15.74"
NETT WEIGHT	1.30kg - 2.87lb	800g - 1.76lb	1.30kg - 2.90lb	1.00kg - 2.20lb

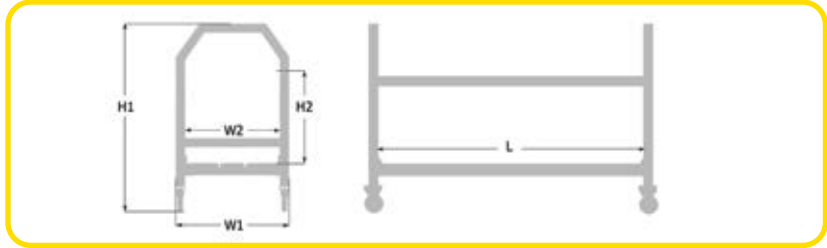

T: +44 (0) 1268 764411
 E: sales@bg-racing.co.uk
 W: www.bg-racing.co.uk

SINGLE TIER WHEEL AND TYRE TROLLEY

Chariot à pneus
 Reifenwagen mit 1 Ebene
 Carrello Porta Gomme Compatto
 Carros para neumáticos

Equally practical for transport in the pit and paddock, or for storage back at the workshop, this Single Tier Wheel and Tyre Trolley is supplied with a pair of 1300mm demountable tyre friendly round cross beams to reduce the marking of tyres, and a central top beam for added strength.

Two fixed and two fully-rotating locking & braking polypropylene castor wheels are supplied as standard, but these can be upgraded to aluminium wheels for towing, or two fully-rotating and two fully-rotating locking & braking polypropylene castor wheels for workshop use.

Manufactured from high-grade mild steel with a durable silver grey powder coated finish.

An optional A-Frame fitted with an M12 Rod End and a Rear Towing Frame are available separately (maximum towing speed of 5mph/8kph). It is recommended that Aluminium Wheels (BGR191P) are used for towing.

Wheel Dividers protect the rim faces by preventing them from rubbing against each other (BGR193).



BGR112P – STANDARD A-FRAME



BGR112PR – REAR TOWING FRAME



BGR193 – WHEEL DIVIDERS (SET OF 3)

OPTIONS	STD A-FRAME	REAR TOWING FRAME	WHEEL DIVIDERS
PART NUMBER	BGR112P	BGR112PR	BGR193
MATERIAL	MILD STEEL	MILD STEEL	MILD STEEL & FOAM
FINISH	POWDER COATED	POWDER COATED	ZINC PLATED
HEIGHT	19mm – 0.75"	70mm – 2.75"	N/A
WIDTH	505mm – 19.88"	40mm – 1.57"	N/A
LENGTH	590mm – 23.22"	450mm – 17.71"	N/A
NETT WEIGHT	1.30kg – 2.87lb	800g – 1.76lb	5.35kg – 11.79lb

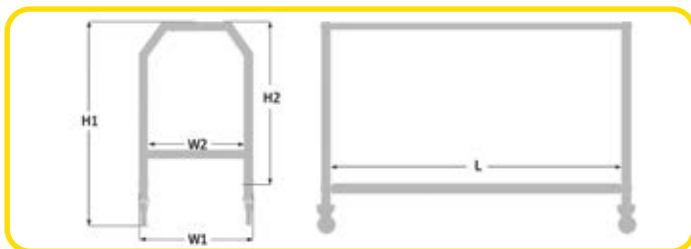

TECHNICAL SPECIFICATIONS

PART NUMBER (PP WHEELS)	BGR190P
PART NUMBER (ALI WHEELS)	BGR191P
PART NUMBER (PP SWIVEL WHEELS)	BGR192P
MATERIAL	MILD STEEL
FINISH	POWDER COATED
HEIGHT (H1)	1030mm – 40.55"
WIDTH (W1)	600mm – 23.62"
INTERNAL LENGTH (L)	1300mm – 51.18"
INTERNAL WIDTH (W2)	450mm – 17.71"
INTERNAL HEIGHT (H2)	698mm – 27.48"
NETT WEIGHT	26.40kg – 58.20lb
LOADING CAPACITY	150kg – 330lb
WHEEL DIAMETER	160mm – 6.29"
WHEEL MATERIAL	POLYPROPYLENE OR ALUMINIUM
TYRE MATERIAL	RUBBER



T: +44 (0) 1268 764411
 E: sales@bg-racing.co.uk
 W: www.bg-racing.co.uk





FOLDING PIT TROLLEY

Chariot de stand pliable
 Klappbarer Boxenwagen
 Carrello pieghevole porta pneumatici
 Carro de transporte plegable



ITEMS SHOWN ON TROLLEY
 NOT INCLUDED

The trolley folds down to take up minimal storage space but is spacious enough to transport wheels, tyres, tools and even Euro Bins around the paddock, pit garage or workshop.

The pit trolley features two fixed and two fully-rotating locking and braking wheels, and a handle allowing it to be easily pulled around the pits or paddock.

Manufactured from high-grade mild steel with a durable silver grey powder coated finish.

Black Nylon Protective Carry Bag and Euro Bins available separately.

TECHNICAL SPECIFICATIONS

PART NUMBER	BGR106P
MATERIAL	MILD STEEL
FINISH	POWDER COATED
HEIGHT (H)	480mm - 18.89"
WIDTH (W)	420mm - 16.53"
LENGTH (L)	1120mm - 44.09"
FOLDED HEIGHT	150mm - 5.90"
FOLDED WIDTH	420mm - 16.53"
FOLDED LENGTH	765mm - 30.11"
NETT WEIGHT	9.60kg - 21.16lb
LOADING CAPACITY	120kg - 264lb
WHEEL DIAMETER	100mm - 3.93"
WHEEL MATERIAL	POLYPROPYLENE
TYRE MATERIAL	RUBBER



OPTIONS

	CARRY BAG	EURO BIN	EURO BIN
PART NUMBER	BGR106BAG	BGR275EB	BGR276EB
MATERIAL	BLACK NYLON	PLASTIC	PLASTIC
HEIGHT	480mm - 18.89"	120mm - 4.72"	120mm - 4.72"
WIDTH	150mm - 5.90"	400mm - 15.74"	300mm - 11.81"
LENGTH	740mm - 29.13"	600mm - 23.62"	400mm - 15.74"
NETT WEIGHT	1.40kg - 3.09lb	1.30kg - 2.90lb	1.00kg - 2.20lb

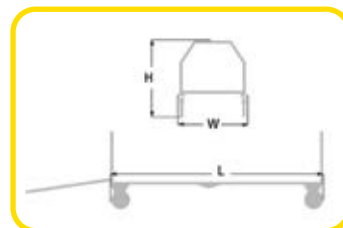

T: +44 (0) 1268 764411
 E: sales@bg-racing.co.uk
 W: www.bg-racing.co.uk

WHEEL AND TYRE DOLLY

Chariot à pneu
 Reifenwagen
 Carrello Portagomme
 Carros para neumáticos

The Wheel and Tyre Dolly is the perfect companion for storing or transporting wheels and tyres around the paddock, pit lane, garage or workshop.

Manufactured from Phenolic Plywood, the Wheel and Tyre Dolly has a non-slip rubberised surface which, when coupled with the lightweight 2-piece mild steel centre pole, keeps your wheels and tyres securely in position.

The Wheel and Tyre Dolly is available 2 diameters; 550mm or 660mm.

The Dolly features four swivelling castor wheels making it easy to manoeuvre, and it can be safely parked with the two braked castor wheels when not in use.

Wheel Protector Foam Discs are an optional extra which are designed to protect the rim faces when stacked vertically on a Wheel and Tyre Dolly.

The thick foam pads are available in either 500mm or 600mm diameters, and the Wheel Protector Foam Discs have a central hole for keeping them in position when used with the central pole on the Wheel and Tyre Dolly.

Sold in a set of 4 discs.



TECHNICAL SPECIFICATIONS

PART NUMBER	BGR185	BGR186
MATERIAL	PLYWOOD & MILD STEEL	PLYWOOD & MILD STEEL
FINISH	RUBBERISED & Z/PLATED	RUBBERISED & Z/PLATED
DIAMETER (D)	550mm - 21.65"	660mm - 25.98"
HEIGHT (H)	1200mm - 47.25"	1200mm - 47.25"
NETT WEIGHT	7.80kg - 17.20lb	9.30kg - 20.50lb
LOADING CAPACITY	150kg - 330.69lb	150kg - 330.69lb
WHEEL DIAMETER	75mm - 2.95"	75mm - 2.95"
WHEEL MATERIAL	POLYPROPYLENE	POLYPROPYLENE
TYRE MATERIAL	RUBBER	RUBBER



OPTIONS

	FOAM DISCS	FOAM DISCS
PART NUMBER	BGR188	BGR189
MATERIAL	FOAM	FOAM
DIAMETER	500mm - 19.69"	600mm - 23.62"
THICKNESS	12.7mm - 0.50"	12.7mm - 0.50"
NETT WEIGHT	0.16kg - 0.35lb	0.32kg - 0.72lb
PACK QUANTITY	4	4



T: +44 (0) 1268 764411
 E: sales@bg-racing.co.uk
 W: www.bg-racing.co.uk





FOLDING UTILITY WORK STATION

Servante atelier pliante
 Klappbarer Papierrollenständer
 Stazione multifunzione pieghevole
 Estación de trabajo plegable



REGISTERED DESIGN

ITEMS SHOWN ON WORK STATION NOT INCLUDED

The Folding Utility Work Station is a must have product for all workshops as it has multi-functional capabilities. The work station includes a tray on the top to hold a small selection of tools, a recessed section for bottles and aerosol cans, a paper roll holder, a waste bin bag holder and an area for a 400mm x 300mm Euro Bin to be fitted where you can store other consumables.

The work station is fitted with 75mm diameter wheels which allow ease of movement around the garage or workshop.

The folding design makes transportation of the work station easy and keeps storage space to a minimum.

Manufactured from high-grade mild steel with a durable silver grey powder coated finish.

Nylon Bin Facade, Euro Bin and Paper Towel Rolls available separately.

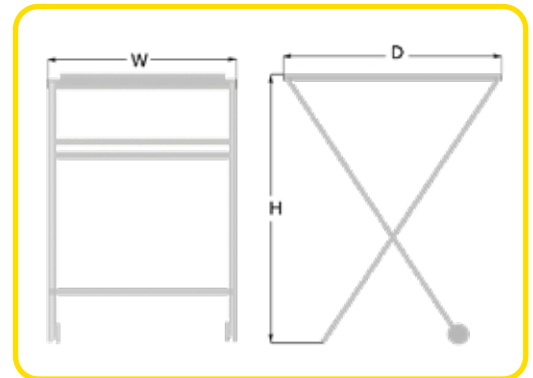

TECHNICAL SPECIFICATIONS

PART NUMBER	BGR109P
MATERIAL	MILD STEEL
FINISH	POWDER COATED
HEIGHT (H)	920mm - 36.22"
WIDTH (W)	520mm - 20.47"
DEPTH (D)	690mm - 27.16"
FOLDED HEIGHT	1125mm - 44.29"
FOLDED WIDTH	520mm - 20.47"
FOLDED DEPTH	80mm - 3.14"
NETT WEIGHT	10.80kg - 23.81lb
TOOL TRAY LOADING CAPACITY	12kg - 26lb
BIN LOADING CAPACITY	10kg - 22lb
PAPER TOWEL LOADING CAPACITY	8kg - 17lb
EURO BIN LOADING CAPACITY	10kg - 22lb
WHEEL DIAMETER	75mm - 2.95"
WHEEL MATERIAL	POLYPROPYLENE
TYRE MATERIAL	RUBBER

OPTIONS

	BIN FACADE	EURO BIN	PAPER TOWEL ROLL
PART NUMBER	BGR109BF	BGR276EB	BGR277
MATERIAL	BLACK NYLON	PLASTIC	PAPER 3PLY
HEIGHT	70mm - 2.75"	120mm - 4.72"	355mm - 13.97"
WIDTH	720mm - 28.34"	300mm - 11.81"	400mm - 15.74"
LENGTH	940mm - 37.00"	400mm - 15.74"	1000 SHEETS
NETT WEIGHT	1.60kg - 3.53lb	1.00kg - 2.20lb	7.50kg - 16.50lb



T: +44 (0) 1268 764411
 E: sales@bg-racing.co.uk
 W: www.bg-racing.co.uk

FOLDING MOBILE WORK STAND

Servante atelier pliante
 Werkstatt-Assistent, klappbar
 Banche da lavoro mobile
 Estación de trabajo plegable

Designed with convenience in mind, the Folding Mobile Work Stand is the perfect workmate around the workshop or garage.

The four swivelling castor wheels make it easy to manoeuvre into place before locking it in position with the two braked castor wheels, and its divided working surface helps keep tools and parts organised.

The Folding Mobile Work Stand provides an ideal work surface to keep tools within reach when under the bonnet or under a vehicle lift and comes with the added benefit folding down for easy transport or storage.

The high-grade mild steel construction and clever folding design gives it a working capacity of 30kgs but minimises overall weight, meaning it can easily be transported and unfolded for use when needed. The durable silver-grey powder coated finish makes it suitable for both indoor and outdoor use.

A 400mm x 300mm Euro Bin (BGR276EB) can be fitted on the supports between the legs for storing your cleaning equipment, parts and consumables.



The **Lightweight Tool Tray** is the perfect companion for carrying loose tools between the workbench and your working area, or at the race circuit from your truck/trailer to the pit lane. It is sized perfectly to sit into the top of the Folding Mobile Work Stand.



EURO BIN AND TOOLS SHOWN ARE NOT INCLUDED

TECHNICAL SPECIFICATIONS

PART NUMBER	BGR179P
MATERIAL	MILD STEEL
FINISH	POWDER COATED
HEIGHT (H)	800mm – 31.5"
WIDTH (W)	500mm – 19.69"
DEPTH (D)	575mm – 22.64"
FOLDED LENGTH	945mm – 37.20"
FOLDED WIDTH	500mm – 19.69"
FOLDED DEPTH	90mm – 3.54"
NETT WEIGHT	10.20kg – 22.49lb
TOOL TRAY LOADING CAPACITY	30.00kg – 66.14lb
EURO BIN LOADING CAPACITY	10kg – 22lb
WHEEL DIAMETER	75mm – 0.29"
WHEEL MATERIAL	POLYPROPYLENE
TYRE MATERIAL	RUBBER

OPTIONS

	EURO BIN	TOOL TRAY
PART NUMBER	BGR276EB	BGR181P
MATERIAL	PLASTIC	MILD STEEL
HEIGHT	120mm – 4.72"	120mm – 4.72"
WIDTH	300mm – 11.81"	190mm – 7.48"
LENGTH	400mm – 15.74"	375mm – 14.76"
NETT WEIGHT	1.00kg – 2.20lb	1.50kg – 3.31lb



T: +44 (0) 1268 764411
 E: sales@bg-racing.co.uk
 W: www.bg-racing.co.uk



LARGE FOLDING TABLE

Table pliante Grand
Klapptisch Groß
Tavolo pieghevole Grande
Mesa plegable Grande



ITEMS SHOWN ON TABLE
NOT INCLUDED



The ideal companion trackside or at home in the workshop, the Large Folding Table features a sturdy 1.8m work surface and folds in half for ease of storage and transportation.

Shelves can be purchased separately along with specifically designed Kart Tyre Rails which can be positioned in several different arrangements to suit the user's requirements and to increase the available storage and working space.

Weight-rated adjustable levelling feet on the bottom of each leg make it quick and easy to achieve a level working surface.

Manufactured from high-grade mild steel with a durable silver grey powder coated finish.



BGR176SHELF - SHELF (SINGLE)



BGR176BAR - KART TYRE RAIL (SINGLE)



OPTIONS

	SHELF (SINGLE)	KART TYRE RAIL (SINGLE)
PART NUMBER	BGR176SHELF	BGR176BAR
MATERIAL	MILD STEEL	MILD STEEL
HEIGHT	23mm - 0.90"	20mm - 0.79"
WIDTH	916mm - 36.06"	912mm - 35.91"
DEPTH	378mm - 14.88"	230mm - 9.06"
NETT WEIGHT	3.00kg - 6.61lb PER SHELF	1.50kg - 3.30lb PER RAIL

TECHNICAL SPECIFICATIONS

PART NUMBER	BGR176P
MATERIAL	MILD STEEL
FINISH	POWDER COATED
HEIGHT (H1)	875mm - 34.45"
HEIGHT (H2)	435mm - 17.13"
HEIGHT (H3)	75mm - 2.95"
WIDTH (W1)	1837mm - 72.32"
WIDTH (W2)	913mm - 35.95"
DEPTH (D)	530mm - 20.87"
FOLDED HEIGHT	140mm - 5.51"
FOLDED WIDTH	919mm - 36.18"
FOLDED DEPTH	530mm - 20.87"
NETT WEIGHT	25.00kg - 55.11lb
TOP SURFACE LOADING CAPACITY	150kg - 330lb
SHELF LOADING CAPACITY	30kg - 66lb PER SHELF
KART RAIL LOADING CAPACITY	10kg - 22lb PER RAIL

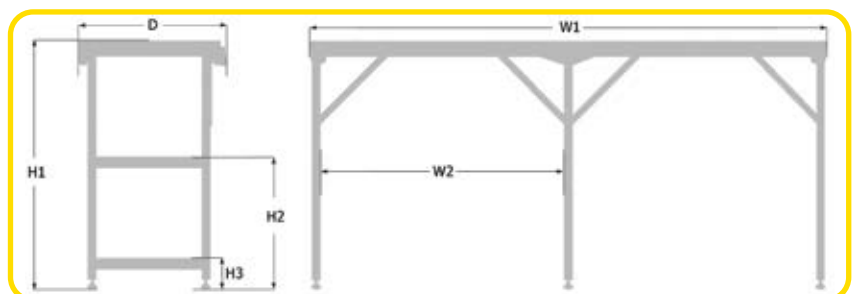

FOLDING WALL MOUNTED TABLE

Table pliante murale
 Klappwerkbank für Wand
 Tavolo da lavoro pieghevole
 montaggio a parete
 Mesa de Pared Plegable



The Folding Wall Table provides a large, sturdy work surface which can be folded away quickly and easily when space is at a premium.

Ideal for use in the garage, workshop or side of your trailer, the Folding Wall Table has a load capacity of 50kg and securely locks in position, making it perfect as a work bench for a multitude of tasks.

The 975mm by 490mm mild steel work top has a durable silver-grey powder coated finish and is big enough to cater for all the tools you are likely to need.

The Wall Mount Bobbin is a machined aluminium fixing designed to be attached to garage, workshop, and trailer walls, allowing the Fold Down Wall Table to be quickly and easily moved between locations with no need for tools.

The Wall Mount Bobbin is designed to fit the keyhole mounting points in the Folding Wall Table, meaning the table is securely fixed in position for use, but can be lifted off and refitted in new positions with ease. Sold in a set of 4.



TECHNICAL SPECIFICATIONS

PART NUMBER	BGR180P
MATERIAL	MILD STEEL
FINISH	POWDER COATED
HEIGHT (H)	275mm - 10.82"
WIDTH (W)	975mm - 38.39"
DEPTH (D)	490mm - 19.29"
FOLDED HEIGHT	90mm - 3.54"
NETT WEIGHT	9.60kg - 21.12lb
LOADING CAPACITY	50kg - 110lb



OPTIONS

	WALL MOUNT BOBBIN
PART NUMBER	BGR182
MATERIAL	ALUMINIUM
DIAMETER	25.4mm - 1.00"
DEPTH	10mm - 0.39"
NETT WEIGHT	0.02kg - 0.04lb
PACK QUANTITY	4



T: +44 (0) 1268 764411
 E: sales@bg-racing.co.uk
 W: www.bg-racing.co.uk



FOLDING PADDOCK TABLE

Table pliante
Klappbarer Arbeitstisch
Tavolo pieghevole
Mesa plegable para boxes



ITEMS SHOWN ON
TABLE NOT INCLUDED

Knowing what life is like in the pits, paddock and back in the workshop, we know how useful it is to have everything to hand, that's why we designed the B-G Racing Folding Paddock Table.

Nearly 1m in width and 0.5m deep, it's large enough to hold a selection of tools and equipment, and the raised table edges will keep them securely on the top surface.

The quick and easy folding design allows for easy transportation and storage. Enhanced feature enables a 400mm x 300mm Euro Bin to be fitted for additional storage.

Manufactured from high-grade mild steel with a durable silver grey powder coated finish.

TECHNICAL SPECIFICATIONS

PART NUMBER	BGR175P
MATERIAL	MILD STEEL
FINISH	POWDER COATED
HEIGHT (H)	830mm - 32.68"
WIDTH (W)	945mm - 37.20"
DEPTH (D)	445mm - 17.52"
FOLDED HEIGHT	1125mm - 44.29"
FOLDED WIDTH	445mm - 17.52"
FOLDED DEPTH	50mm - 1.96"
NETT WEIGHT	8.20kg - 18.08lb
TOP SURFACE LOADING CAPACITY	30kg - 66lb
EURO BIN LOADING CAPACITY	10kg - 22lb

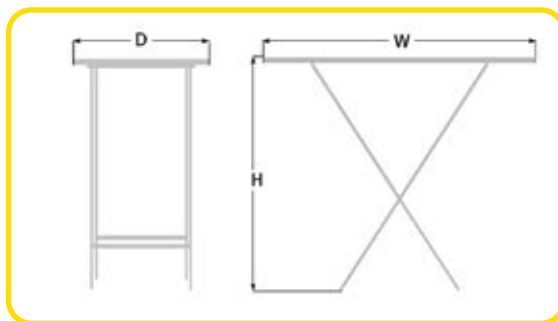

OPTIONS

EURO BIN	
PART NUMBER	BGR276EB
MATERIAL	PLASTIC
HEIGHT	120mm - 4.72"
WIDTH	300mm - 11.81"
LENGTH	400mm - 15.74"
NETT WEIGHT	1.00kg - 2.20lb

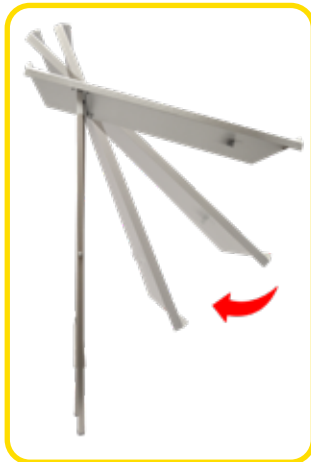

WHEEL AND TYRE CLEANING BATH

Machine à laver des roues et pneu

Reifenwaschtisch

Serbatoio pulizia per il ruote e pneumatici

Baño de limpieza de ruedas y neumáticos

The Wheel and Tyre Cleaning Bath is the perfect solution for reducing mess and controlling waste, whilst bringing wheel and tyre cleaning up to a comfortable working level.

The framework is manufactured from high-grade mild steel with a durable black finish, the Wheel and Tyre Cleaning Bath features adjustable width stainless steel rollers to suit different wheel or tyre diameters. The bath can also be used for washing rims only. A stainless steel drain with a filter element is fitted in the bottom of the bath. The wastewater can either be held in the bath or drained through the supplied hose into a nearby drain or container, depending on the circuit requirements.

The bath can be quickly detached from the frame by releasing detent pins and the legs fold flat for ease of storage and transportation.

A 400mm x 300mm Euro Bin can be fitted on the supports between the legs for storing your cleaning equipment and consumables.



WHEEL AND EURO BIN SHOWN ON BATH NOT INCLUDED

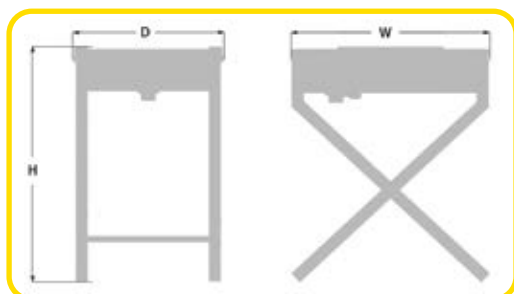

TECHNICAL SPECIFICATIONS

PART NUMBER	BGR178
MATERIAL	MILD STEEL & STAINLESS STEEL
FINISH	BLACK
HEIGHT (H)	790mm – 31.10"
WIDTH (W)	670mm – 26.38"
DEPTH (D)	520mm – 20.47"
NETT WEIGHT	16.50kgs – 36.30lb
TOP SURFACE LOADING CAPACITY	60.00kg – 132.27lb
EURO BIN LOADING CAPACITY	10kg – 22lb

OPTIONS

	EURO BIN
PART NUMBER	BGR276EB
MATERIAL	PLASTIC
HEIGHT	120mm – 4.72"
WIDTH	300mm – 11.81"
LENGTH	400mm – 15.74"
NETT WEIGHT	1.00kg – 2.20lb



T: +44 (0) 1268 764411
 E: sales@bg-racing.co.uk
 W: www.bg-racing.co.uk



SINGLE AIR/GAS BOTTLE TROLLEY

Chariot pour bouteille

Flaschenwagen für 1 Druckluftflasche

Carrello per Bombola singola

Carro Botella



BOTTLE AND REGULATOR SHOWN ON TROLLEY NOT INCLUDED

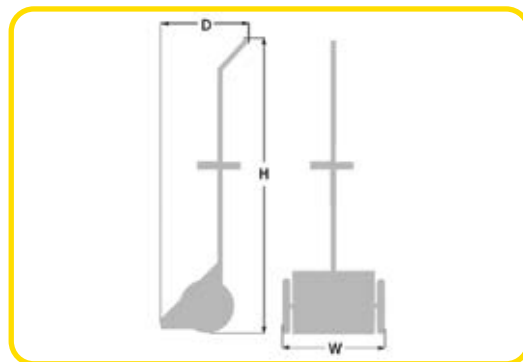

TECHNICAL SPECIFICATIONS

PART NUMBER	BGR194P
MATERIAL	MILD STEEL
FINISH	POWDER COATED
HEIGHT (H)	1220mm - 48.00"
WIDTH (W)	420mm - 16.54"
DEPTH (D)	330mm - 12.99"
WHEEL DIAMETER	200mm - 7.87"
WHEEL MATERIAL	POLYPROPYLENE
TYRE MATERIAL	RUBBER
NETT WEIGHT	7.50kg - 16.53lb
LOADING CAPACITY	35kg - 77.16lb



T: +44 (0) 1268 764411
 E: sales@bg-racing.co.uk
 W: www.bg-racing.co.uk

BATTERY TROLLEYS

Chariot de batterie

Batteriewagen

Carrello porta batteria

Carro para el transport de bateria

Engineered for quick and easy transportation, tough and durable, the B-G Racing Battery Trolleys are ideal for transporting a slave battery around the pits, paddock and workshop.

With two variations available, one designed specifically for carrying only a battery and the second including an additional tray to carry a small selection of tools etc.

Attention to detail includes a removable handle, and a bracket with clamp to secure the battery firmly.

Manufactured from high-grade mild steel with a durable silver grey powder coated finish.



BATTERIES AND CABLES SHOWN ON TROLLEYS NOT INCLUDED

BGR100P – BATTERY TROLLEY SINGLE TRAY

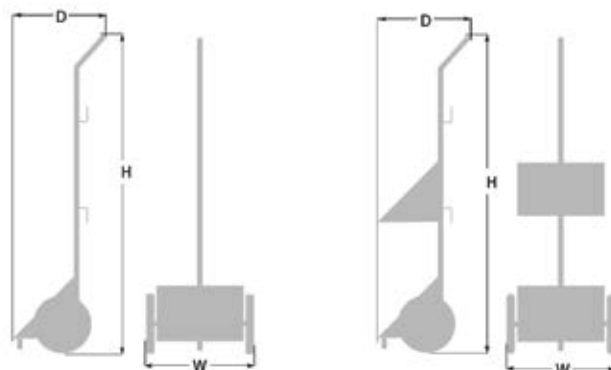

BGR101P – BATTERY TROLLEY DOUBLE TRAY



TECHNICAL SPECIFICATIONS

PART NUMBER	BGR100P (SINGLE TRAY)	BGR101P (DOUBLE TRAY)
MATERIAL	MILD STEEL	MILD STEEL
FINISH	POWDER COATED	POWDER COATED
LENGTH	295mm – 11.61"	295mm – 11.61"
HEIGHT (H)	1220mm – 48.03"	1220mm – 48.03"
WIDTH (W)	410mm – 16.14"	410mm – 16.14"
DEPTH (D)	260mm – 10.24"	260mm – 10.24"
NETT WEIGHT	5.10kg – 11.22lb	6.30kg – 13.89lb
BATTERY TRAY LOADING CAPACITY	25kg – 55lb	25kg – 55lb
TOOL TRAY LOADING CAPACITY	N/A	5kg – 11lb
WHEEL DIAMETER	200mm – 7.87"	200mm – 7.87"
WHEEL MATERIAL	POLYPROPYLENE	POLYPROPYLENE
TYRE MATERIAL	RUBBER	RUBBER



T: +44 (0) 1268 764411
 E: sales@bg-racing.co.uk
 W: www.bg-racing.co.uk





FUEL BOTTLE STAND - PREMIER BOTTLE



FUEL BOTTLE
NOT INCLUDED

Support de bidon
Ständer für Betankungsanlage
Supporto per tanica
Soporte para botellas de repostaje

This Fuel Bottle Stand offers a sturdy storage solution for the Premier Refuelling Bottle Assembly.

Manufactured from high-grade mild steel with a durable black EDP coating, the stand has been designed to be assembled and disassembled for ease of storage and transportation.

Featuring an adjustable strap to firmly hold the bottle in position when it is being filled and adjustable feet to ensure the stand is level to the ground.

The stand is suitable for various configurations of the Premier Refuelling Bottle, including the Single or Double, Straight or Angled connectors and those bottles with additional breather pipes.

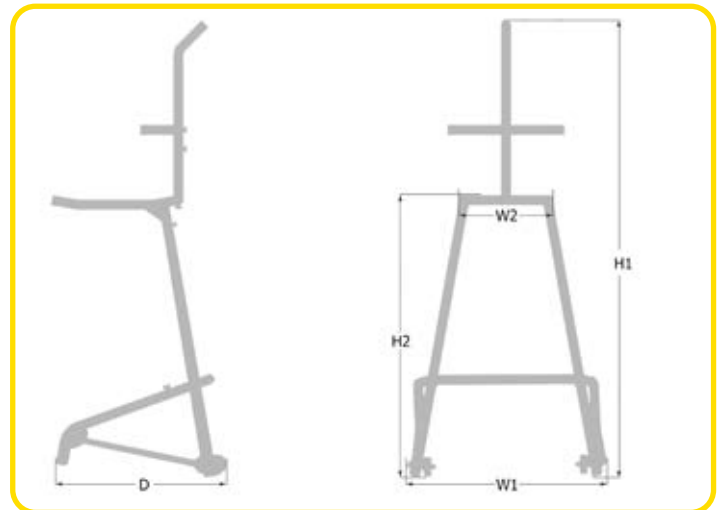

TECHNICAL SPECIFICATIONS

PART NUMBER	BGR131
MATERIAL	MILD STEEL
COLOUR	BLACK
FINISH	EDP COATED
HEIGHT (H1)	1205mm – 47.44"
HEIGHT (H2)	725mm – 28.54"
WIDTH (W1)	540mm – 21.26"
WIDTH (W2)	225mm – 8.86"
DEPTH (D)	450mm – 17.72"
WHEEL DIAMETER	50mm – 2"
WHEEL MATERIAL	RUBBER & NYLON
NETT WEIGHT	6.60kg – 14.55lb
LOADING CAPACITY	35kg – 77.16lb



T: +44 (0) 1268 764411
E: sales@bg-racing.co.uk
W: www.bg-racing.co.uk

FUEL BOTTLE STAND - ATL BOTTLE

Support de bidon
Ständer für Betankungsanlage
Supporto per tanica
Soporte para botellas de repostaje

The Fuel Bottle Stand for the ATL Refuelling Bottle Assembly is designed with convenience and usability in mind.

Manufactured from high-grade mild steel with a durable black EDP coating, the stand has been designed to be assembled and disassembled for ease of storage and transportation and can stand upright for bottle storage or lay flat for level filling.

The stand is suitable for various configurations of the ATL Refuelling Bottle, including the Single or Double, Straight or Angled connectors and those bottles with additional breather pipes.

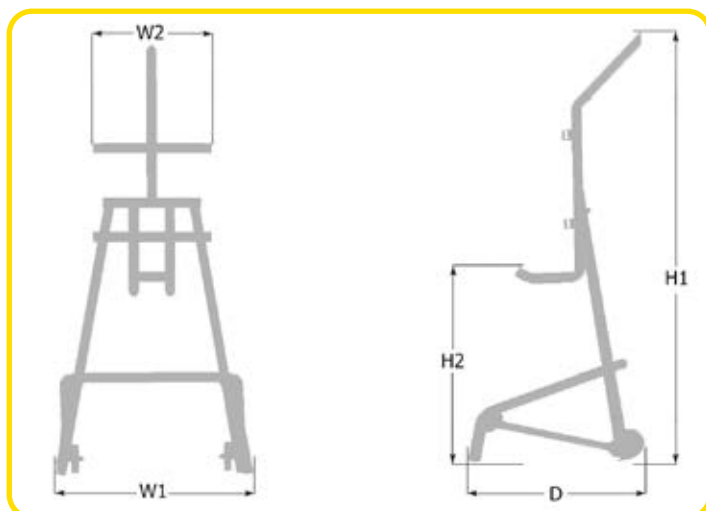

TECHNICAL SPECIFICATIONS

PART NUMBER	BGR132
MATERIAL	MILD STEEL
COLOUR	BLACK
FINISH	EDP COATED
HEIGHT (H1)	1190mm – 46.85"
HEIGHT (H2)	515mm – 20.28"
WIDTH (W1)	540mm – 21.26"
WIDTH (W2)	320mm – 12.60"
DEPTH (D)	450mm – 17.72"
WHEEL DIAMETER	50mm – 2"
WHEEL MATERIAL	RUBBER & NYLON
NETT WEIGHT	6.00kg – 13.2lb
LOADING CAPACITY	35kg – 77.16lb



T: +44 (0) 1268 764411
E: sales@bg-racing.co.uk
W: www.bg-racing.co.uk





QUICK LIFT JACKS

Lève rapide
Schnellheber
Sollevatori rapidi
Gato de elevación rápida

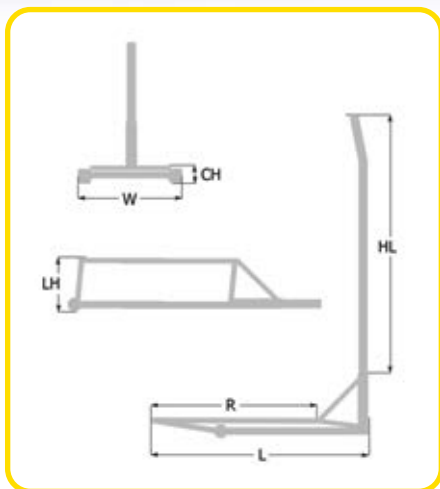

BGR157P / BGR157RED –
SMALL FORMULA QUICK LIFT JACK

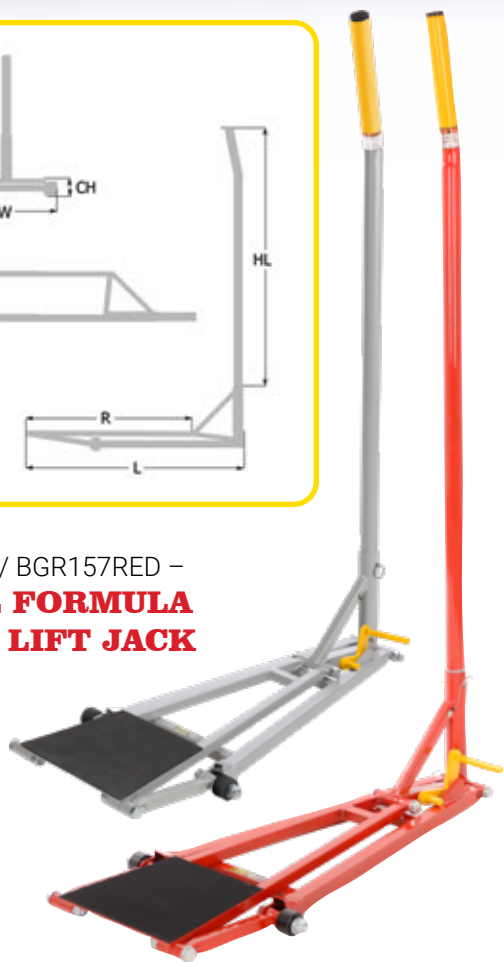

Engineered and manufactured with durability and ease of use in mind, B-G Racing Quick Lift Jacks are suitable for a wide range of vehicles, including formula, saloon and rally.

All feature a very low closed height and are designed to locate beneath the differential and front or rear chassis members, raising the car to a fixed height in one swift movement. A safety locking device which is quick and easy to use ensures the handle cannot be raised unless intended.

Produced from high-grade mild steel with a durable silver grey or red powder coated finish for longevity. Design detail includes an extra long, ergonomic handle for excellent leverage with a yellow tip to enhance visibility and nylon roller wheels to allow easy manoeuvrability.

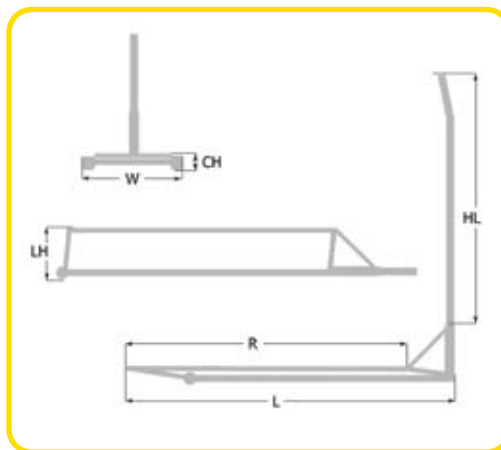

BGR156P / BGR156RED –
LONG FORMULA QUICK LIFT JACK

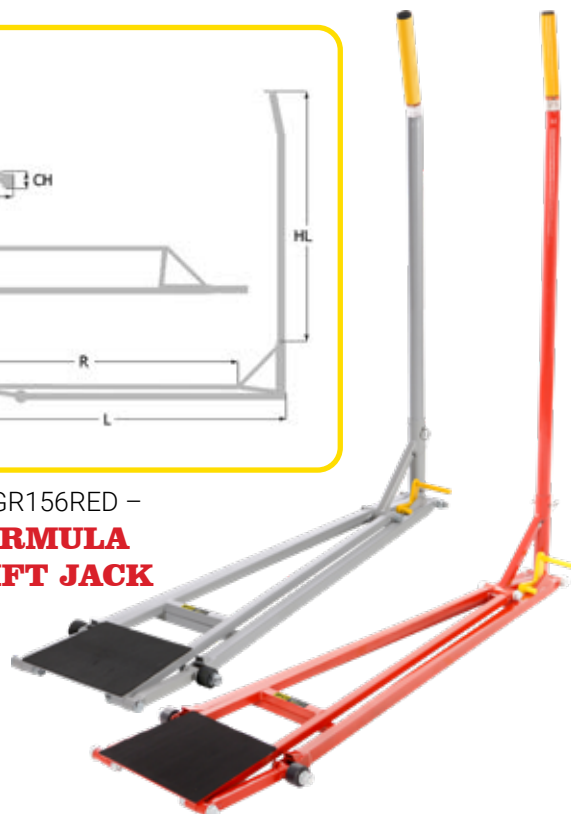

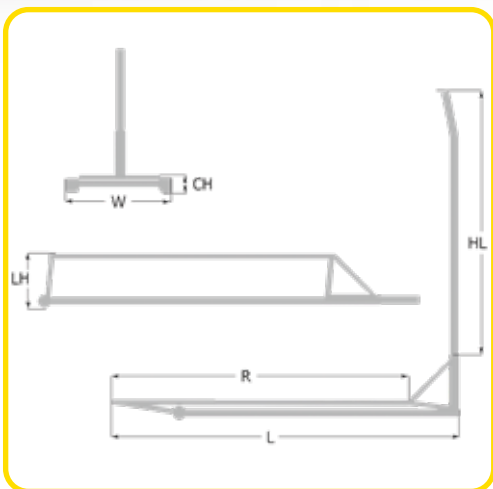

BGR155P / BGR155RED –
**TRACK SALOON
QUICK LIFT JACK**

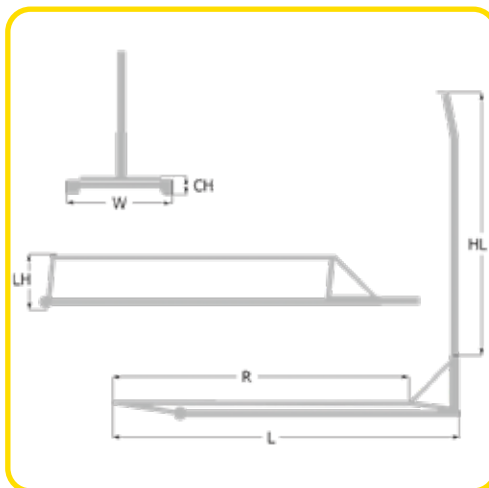

BGR154P / BGR154RED –
**RALLY QUICK
LIFT JACK**

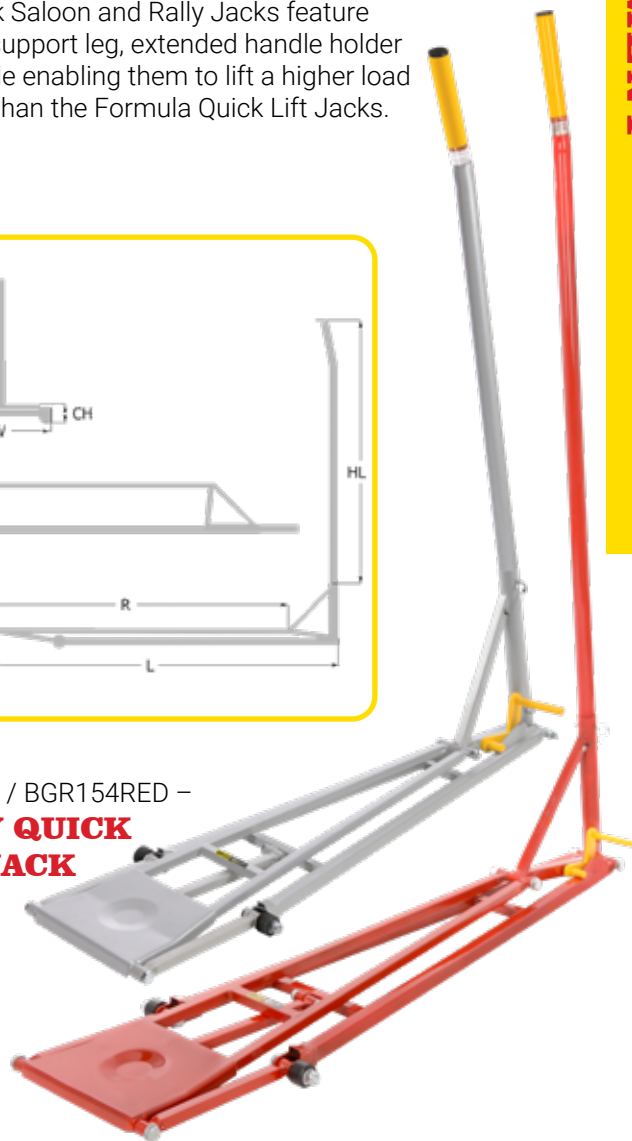

TECHNICAL SPECIFICATIONS

PART NUMBER	BGR157P / BGR157RED	BGR156P / BGR156RED	BGR155P / BGR155RED	BGR154P / BGR154RED
MATERIAL	MILD STEEL	MILD STEEL	MILD STEEL	MILD STEEL
FINISH	POWDER COATED	POWDER COATED	POWDER COATED	POWDER COATED
LENGTH (L)	790mm – 31.10"	1190mm – 46.85"	1190mm – 46.85"	1290mm – 50.78"
WIDTH (W)	370mm – 14.56"	370mm – 14.56"	370mm – 14.56"	370mm – 14.56"
CLOSED HEIGHT (CH)	50mm – 1.96"	50mm – 1.96"	50mm – 1.96"	55mm – 2.16"
LIFTING HEIGHT (LH)	210mm – 8.26"	210mm – 8.26"	210mm – 8.26"	295mm – 11.61"
REACH (R)	570mm – 22.44"	980mm – 38.58"	980mm – 38.58"	990mm – 38.97"
HANDLE LENGTH (HL)	1080mm – 42.51"	1080mm – 42.51"	1280mm – 50.39"	1280mm – 50.39"
NETT WEIGHT	10.00kg – 22.05lb	11.30kg – 24.91lb	13.30kg – 29.32lb	14.40kg – 31.75lb
LIFTING CAPACITY	300kg – 660lb	300kg – 660lb	400kg – 880lb	400kg – 880lb
WHEEL DIAMETER	35.50mm – 1.37"	35.50mm – 1.37"	35.50mm – 1.37"	35.50mm – 1.37"
WHEEL MATERIAL	NYLON	NYLON	NYLON	NYLON



T: +44 (0) 1268 764411
E: sales@bg-racing.co.uk
W: www.bg-racing.co.uk



FORMULA REAR SWIVEL JACK



Lève rapide formule arrière
 Heckheber mit drehbarem Oberteil
 Sollevatore posteriore per formula
 Gato de palanca trasero para Fórmulas



The B-G Racing Formula Rear Swivel Jack is designed to fit any single-seater with jack-locating lugs on the gearbox or rear wing.

Engineered for strength and manoeuvrability the swivel jack is height adjustable and utilises large diameter wheels.

Enhanced features include a T-bar grip for quick and accurate positioning beneath the car. A detachable handle makes for ease of transportation and storage.

Manufactured from high-grade mild steel with a durable silver grey powder coated finish.



TECHNICAL SPECIFICATIONS

PART NUMBER	BGR153P
MATERIAL	MILD STEEL
FINISH	POWDER COATED
LENGTH (L)	1530mm – 60.23"
WIDTH (W1)	325mm – 12.79"
WIDTH (W2)	172mm – 6.77"
LIFTING HEIGHTS	320mm – 12.59"
	335mm – 13.18"
	365mm – 14.37"
	380mm – 14.96"
NETT WEIGHT	9.80kg – 21.61lb
LIFTING CAPACITY	350kg – 770lb
WHEEL DIAMETER	200mm – 7.87"
WHEEL MATERIAL	POLYPROPYLENE
TYRE MATERIAL	RUBBER

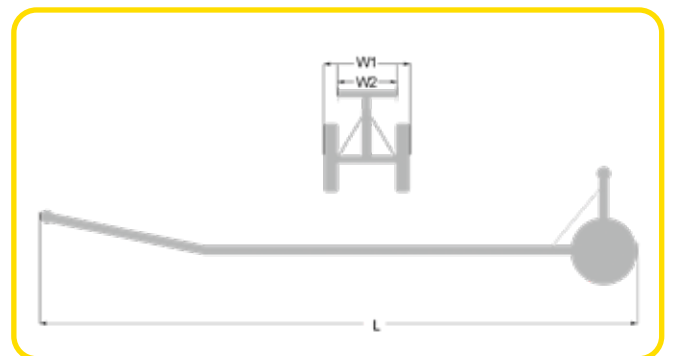

T: +44 (0) 1268 764411
 E: sales@bg-racing.co.uk
 W: www.bg-racing.co.uk

WIDE BODY QUICK LIFT JACK

Lève rapide
Schnellheber
Sollevatori rapidi
Gato de elevación rápida

Engineered and manufactured with durability and ease of use in mind, the Wide Body Quick Lift Jack is suitable for various historic formula and sports cars which require a wider lifting platform.

Featuring a low closed height and wide lifting pad designed to raise the car to a fixed height in one swift movement. A safety locking device which is quick and easy to use ensures the handle cannot be raised unless intended.

Produced from high-grade mild steel with a durable silver grey powder coated finish for longevity. Design detail includes a heavy duty, ergonomic handle for excellent leverage with a yellow tip to enhance visibility and nylon roller wheels to allow easy manoeuvrability.

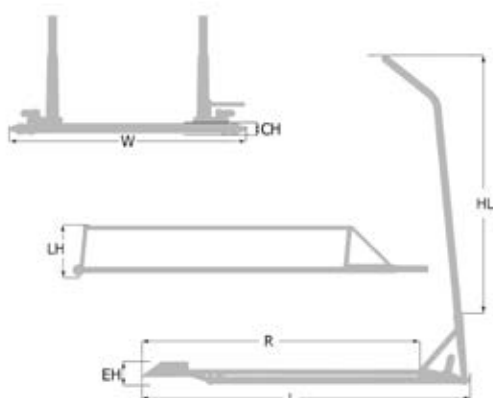

TECHNICAL SPECIFICATIONS

PART NUMBER	BGR158P
MATERIAL	MILD STEEL
FINISH	POWDER COATED
LENGTH (L)	1080mm – 42.52"
WIDTH (W)	700mm – 27.56"
CLOSED HEIGHT (CH)	45mm – 1.77"
ENTRY HEIGHT (EH)	25mm – 0.98"
LIFTING HEIGHT (LH)	125mm – 4.92"
REACH (R)	900mm – 35.43"
HANDLE LENGTH (HL)	1050mm – 41.34"
LIFTING CAPACITY	250kg – 551.16lb
WHEEL DIAMETER	32mm – 1.25"
WHEEL MATERIAL	NYLON
NETT WEIGHT	13.80kg – 30.42lb



T: +44 (0) 1268 764411
E: sales@bg-racing.co.uk
W: www.bg-racing.co.uk





SILL STANDS

Chandelles professionnelles
Standböcke für Rallye
Coppia cavalletti rally
Borriquetas para asistencia

Designed for use with vehicles fitted with receptacle tubes in the sills, these heavy-duty Sill Stands allow improved access to the vehicle to carry out maintenance tasks quickly and efficiently.

Each stand features a handy storage tray as well as two threaded bosses in the base designed to accommodate the B-G Racing Levelling Feet (available separately) for use on uneven ground or to increase the height of the stand.

Manufactured from high-grade mild steel with a durable silver grey powder coated finish and zinc plated pins.

Sold in a set of 4 with either 20mm or 25mm pins.

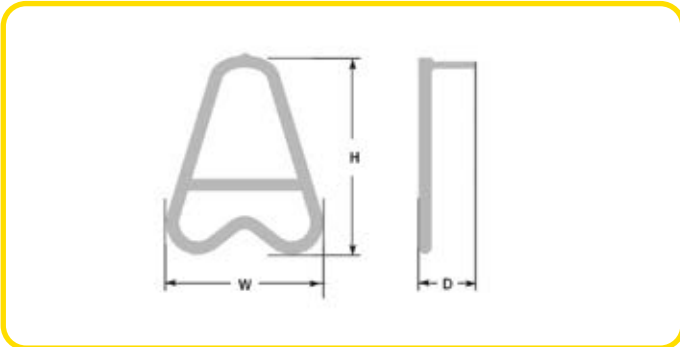

TECHNICAL SPECIFICATIONS

PART NUMBER	BGR129	BGR130
MATERIAL	MILD STEEL	MILD STEEL
FINISH	POWDER COATED	POWDER COATED
PIN SIZE	20mm	25mm
HEIGHT (H)	590mm – 23.23"	590mm – 23.23"
WIDTH (W)	470mm – 18.50"	470mm – 18.50"
DEPTH (D)	170mm – 6.70"	170mm – 6.70"
LOADING CAPACITY	500kg – 1102lb PER STAND	500kg – 1102lb PER STAND
NETT WEIGHT	3.80kg – 8.38lb PER STAND	3.80kg – 8.38lb PER STAND

OPTIONS

PART NUMBER	LEVELLING FEET (SET OF 4)
MATERIAL	BGR357 STEEL
FINISH	ZINC PLATED
THREAD SIZE	M12
NETT WEIGHT	260g – 0.57lb PER FOOT



T: +44 (0) 1268 764411
E: sales@bg-racing.co.uk
W: www.bg-racing.co.uk

CHASSIS STANDS

Tréteaux de chassis

Chassisständer

Cavalletti fissi e pieghevoli

Caballetes

A range of four B-G Racing Chassis Stands in differing heights and widths have been created to fulfil a wide range of requirements both trackside and in the workshop.

The stands are robustly manufactured from high-grade mild steel with a silver grey or red powder coated finish for long-term durability.

They feature a large footprint for stability and flat feet on the Small and Medium Chassis Stands to prevent damage to the floor and work surface. The Large and Extra Large Chassis Stands fold down for ease of transportation and storage.

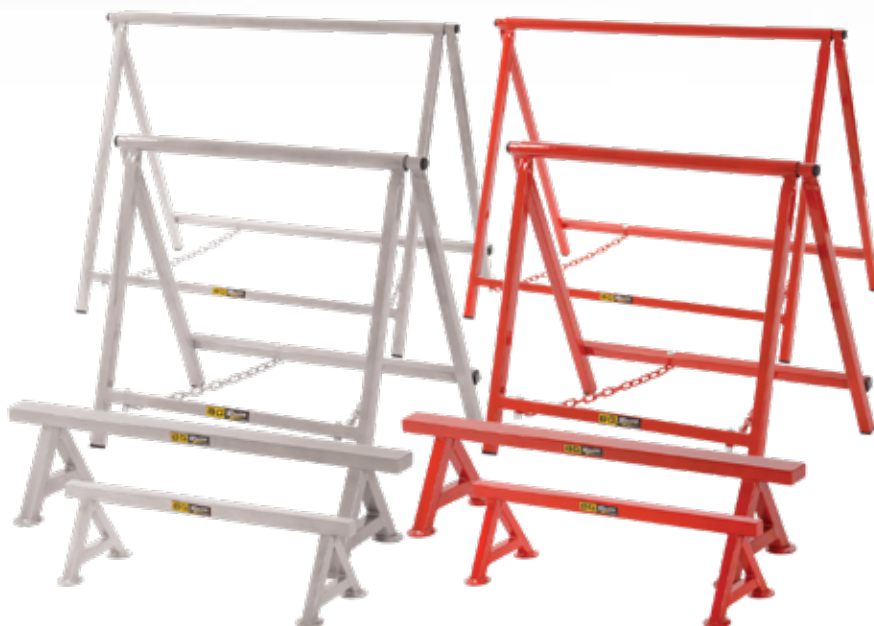

BGR127P / BGR127RED / BGR128P / BGR128RED

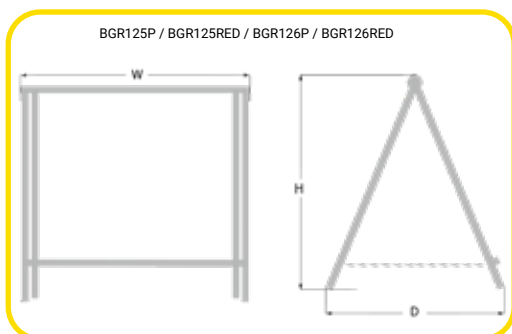

BGR125P / BGR125RED / BGR126P / BGR126RED

TECHNICAL SPECIFICATIONS

PART NUMBER	BGR125P / BGR125RED	BGR126P / BGR126RED	BGR127P / BGR127RED	BGR128P / BGR128RED
MATERIAL	MILD STEEL	MILD STEEL	MILD STEEL	MILD STEEL
FINISH	POWDER COATED	POWDER COATED	POWDER COATED	POWDER COATED
HEIGHT (H)	610mm - 24"	457mm - 18"	178mm - 7"	152mm - 6"
WIDTH (W)	787mm - 31"	533mm - 21"	762mm - 30"	559mm - 22"
DEPTH (D)	490mm - 19.29"	265mm - 10.43"	230mm - 9.05"	195mm - 7.67"
NETT WEIGHT	10.00kg - 22.05lb PER PAIR	7.00kg - 14.99lb PER PAIR	5.00kg - 10.58lb PER PAIR	3.00kg - 5.73lb PER PAIR
LOADING CAPACITY	300kg - 660lb EACH	300kg - 660lb EACH	300kg - 660lb EACH	300kg - 660lb EACH



T: +44 (0) 1268 764411
 E: sales@bg-racing.co.uk
 W: www.bg-racing.co.uk





VEHICLE RAMPS

Rampes de levage
 Auffahrrampen
 Rampe auto
 Rampas de coche



The B-G Racing Vehicle Ramps are available in either Low Rise, Low Rise Split or Mid Rise versions, perfect for various applications.



The Low Rise Vehicle Ramps are a great solution to a problem commonly faced by many race teams, mechanics and vehicle owners. They are ideal for use on lowered vehicles and race cars as the gentle gradient elevates the car an additional 70mm off the ground allowing for easier and safer access for trolley jacks.



The Low Rise Split Vehicle Ramps have the additional benefit of splitting in the middle, which allows for easier access to side jacking points once the vehicle is on the ramps.

Providing 110mm of lift, the Mid Rise Vehicle Ramps are great for quick under-body maintenance tasks and provide enough clearance for trolley jacks to safely access the underside of the vehicle. The gentle gradient makes them suitable for use on most lowered vehicles, sports cars, rally cars and race cars.

The Vehicle Ramps are produced from a durable black Polypropylene (PP) and have a combined weight loading capacity of 5000kg.



TECHNICAL SPECIFICATIONS

PART NUMBER	BGR225	BGR226	BGR228
MATERIAL	POLYPROPYLENE	POLYPROPYLENE	POLYPROPYLENE
FINISH	SMOOTH	SMOOTH	SMOOTH
LENGTH (L)	700mm - 27.55"	810mm - 31.89"	700mm - 27.55"
WIDTH (W1)	190mm - 7.48"	190mm - 7.48"	190mm - 7.48"
WIDTH (W2)	200mm - 7.87"	205mm - 8.07"	200mm - 7.87"
HEIGHT (H1)	70mm - 2.75"	110mm - 4.33"	70mm - 2.75"
HEIGHT (H2)	80mm - 3.14"	125mm - 4.92"	80mm - 3.14"
NETT WEIGHT	2.80kg - 6.17lb	4.40kg - 9.70lb	2.80kg - 6.17lb
LOADING CAPACITY	5000kg - 11000lb PER PAIR	5000kg - 11000lb PER PAIR	5000kg - 11000lb PER PAIR



T: +44 (0) 1268 764411
 E: sales@bg-racing.co.uk
 W: www.bg-racing.co.uk

TYRE CHANGING RAMP

Rampe changement de roue
 Auffahrbock für Reifenwechsel
 Rampa di sollevamento
 Rampas para Cambio de Neumáticos



Save time and energy when replacing flat or punctured tyres.

Designed for use on twin axle trailers, the Tyre Changing Ramp simplifies the wheel changing process. Simply loosen the wheel nuts/bolts on the damaged wheel and drive the good wheel onto the Tyre Changing Ramp. The damaged wheel is then suspended off the ground allowing for work to be carried out safely and efficiently, before driving the trailer back off the ramp and re-tightening the nuts/bolts.

No more messing around with jacks or makeshift shims, one of these Tyre Changing Ramps can be easily stored in the back of the trailer and quickly used in the event of experiencing a puncture in the future.

Sold individually.

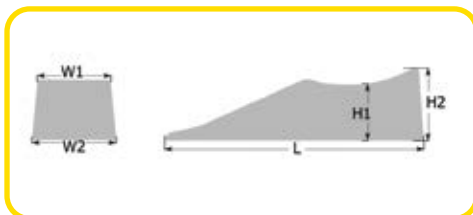

TECHNICAL SPECIFICATIONS

PART NUMBER	BGR227
MATERIAL	POLYPROPYLENE
FINISH	SMOOTH
LENGTH (L)	610mm - 24.02"
WIDTH (W1)	205mm - 8.07"
WIDTH (W2)	215mm - 8.47"
HEIGHT (H1)	140mm - 5.51"
HEIGHT (H2)	180mm - 7.09"
NETT WEIGHT	3.10kg - 6.83lb PER RAMP
LOADING CAPACITY	7000kg - 15432lb PER RAMP



T: +44 (0) 1268 764411
 E: sales@bg-racing.co.uk
 W: www.bg-racing.co.uk





STANDARD ALUMINIUM PIT BOARD AND NUMBERS

Panneautage
Boxentafel
Tabella Box
Pizarra Tiempos



A pit board is a must have in almost all forms of motorsport. Our Pit Boards have been created to fulfill the requirements of race teams by offering a choice of two different size boards which can be purchased separately or as part of a complete kit with Carry Bag and Number Set.

The Standard Pit Board is manufactured from lightweight T6 Aluminium with four colour options; red, blue, black or bright silver. All finishes are durable and hard wearing for longevity.

An optional Name Plate is the ideal solution for those who struggle to pick out their pit board amongst the crowd. Produced from 3mm thick foam PVC, it is perfect for personalising with a driver's name, number or logo and creates a professional appearance. It simply pushes into the Standard Aluminium Pit Board.

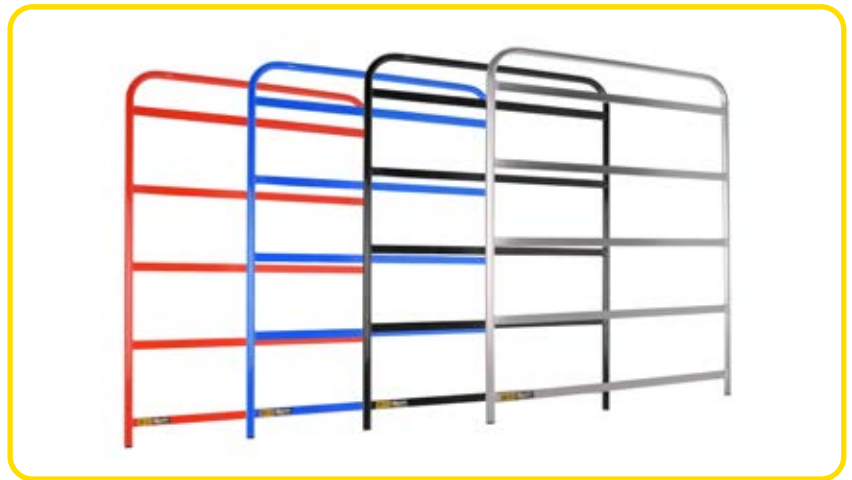
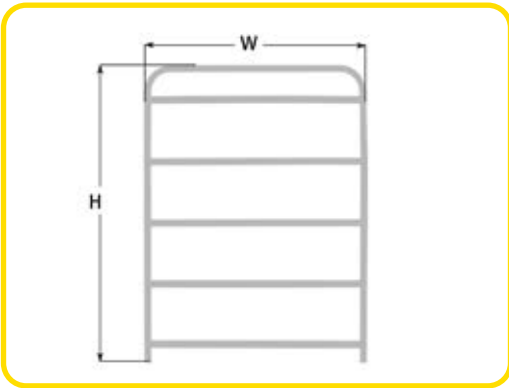

NAME PLATE

PART NUMBER	BGR264
MATERIAL	PVC FOAM
COLOUR	SATIN BLACK
HEIGHT	172mm - 6.77"
WIDTH	590mm - 23.23"
NETT WEIGHT	160g - 0.35lb

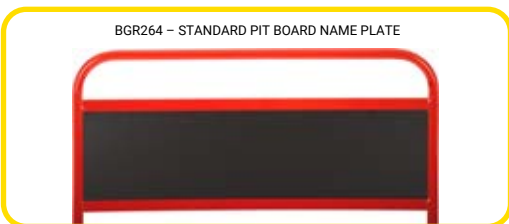

STANDARD PIT BOARDS

PART NUMBER	BGR261	BGR261RED	BGR261BLU	BGR261BLA
MATERIAL	T6 ALUMINIUM	T6 ALUMINIUM	T6 ALUMINIUM	T6 ALUMINIUM
COLOUR	SILVER	RED	BLUE	BLACK
ROWS	4	4	4	4
HEIGHT (H)	830mm - 32.68"	830mm - 32.68"	830mm - 32.68"	830mm - 32.68"
WIDTH (W)	630mm - 24.80"	630mm - 24.80"	630mm - 24.80"	630mm - 24.80"
NETT WEIGHT	960g - 2.12lb	960g - 2.12lb	960g - 2.12lb	960g - 2.12lb



The Standard Pit Board Kits include a full set of Hi-Vis Numbers and a protective Carry Bag that features internal pockets to keep the Number Set organised.

The 38 piece number set for the Standard Aluminium Pit Board includes numbers, letters, word and symbols. Available in a choice of Hi-Vis Green, Hi-Vis Orange, Hi-Vis Pink, White or Hi-Vis Yellow colours.

A unique feature is that each number, letter, words and symbol features a smaller icon in the top left hand corner to make it easily identifiable when stored in the bag pockets.

The bag is produced from Nylon fabric and features flaps to ensure the numbers do not fall out during transportation and a pair of removable and adjustable straps to make it easier to secure the bag to a pit wall.

The number sets and the bag can also be purchased separately.



STANDARD PIT BOARD NUMBERS

PART NUMBER	BGR262G	BGR262O	BGR262P	BGR262	BGR262Y
MATERIAL	HIPS	HIPS	HIPS	HIPS	HIPS
COLOUR	GREEN	ORANGE	PINK	WHITE	YELLOW
HEIGHT	178mm - 7.00"	178mm - 7.00"	178mm - 7.00"	178mm - 7.00"	178mm - 7.00"
WIDTH	126mm - 4.96"	126mm - 4.96"	126mm - 4.96"	126mm - 4.96"	126mm - 4.96"
NETT WEIGHT	800g - 1.76lb	800g - 1.76lb	800g - 1.76lb	800g - 1.76lb	800g - 1.76lb
NUMBERS	3x 0-9	3x 0-9	3x 0-9	3x 0-9	3x 0-9
LETTERS	1x P, L & T	1x P, L & T	1x P, L & T	1x P, L & T	1x P, L & T
WORDS	1x FUEL & IN	1x FUEL & IN	1x FUEL & IN	1x FUEL & IN	1x FUEL & IN
SYMBOLS	1x +, - & .	1x +, - & .	1x +, - & .	1x +, - & .	1x +, - & .

STANDARD PIT BOARD BAG

PART NUMBER	BGR263
MATERIAL	BLACK NYLON
FINISH	TEXTURED
HEIGHT	920mm - 36.22"
WIDTH	690mm - 27.17"
NETT WEIGHT	3.40kg - 7.50lb

STANDARD PIT BOARD KITS

PART NUMBER	SILVER BOARD, NUMBERS AND BAG	RED BOARD, NUMBERS AND BAG	BLUE BOARD, NUMBERS AND BAG	BLACK BOARD, NUMBERS AND BAG
	BGR260G (GREEN NUMBERS IN KIT)	BGR260RED-G (GREEN NUMBERS IN KIT)	BGR260BLU-G (GREEN NUMBERS IN KIT)	BGR260BLA-G (GREEN NUMBERS IN KIT)
	BGR260O (ORANGE NUMBERS IN KIT)	BGR260RED-O (ORANGE NUMBERS IN KIT)	BGR260BLU-O (ORANGE NUMBERS IN KIT)	BGR260BLA-O (ORANGE NUMBERS IN KIT)
	BGR260P (PINK NUMBERS IN KIT)	BGR260RED-P (PINK NUMBERS IN KIT)	BGR260BLU-P (PINK NUMBERS IN KIT)	BGR260BLA-P (PINK NUMBERS IN KIT)
	BGR260 (WHITE NUMBERS IN KIT)	BGR260RED-W (WHITE NUMBERS IN KIT)	BGR260BLU-W (WHITE NUMBERS IN KIT)	BGR260BLA-W (WHITE NUMBERS IN KIT)
	BGR260Y (YELLOW NUMBERS IN KIT)	BGR260RED-Y (YELLOW NUMBERS IN KIT)	BGR260BLU-Y (YELLOW NUMBERS IN KIT)	BGR260BLA-Y (YELLOW NUMBERS IN KIT)



T: +44 (0) 1268 764411
 E: sales@bg-racing.co.uk
 W: www.bg-racing.co.uk





LARGE ALUMINIUM PIT BOARD AND NUMBERS

Panneautage Grand
 Boxentafel Groß
 Tabella Box Grande
 Pizarra Tiempos Grande

The Large Pit Board consists of a tubular frame and features an ergonomic handle. Designed with four rows for displaying information and a top plate that can be personalised with a driver's name, number or team logo.

Manufactured from lightweight T6 Aluminium with a durable silver or black finish.

The board can be purchased separately or as part of a complete kit with Carry Bag and Number Set.

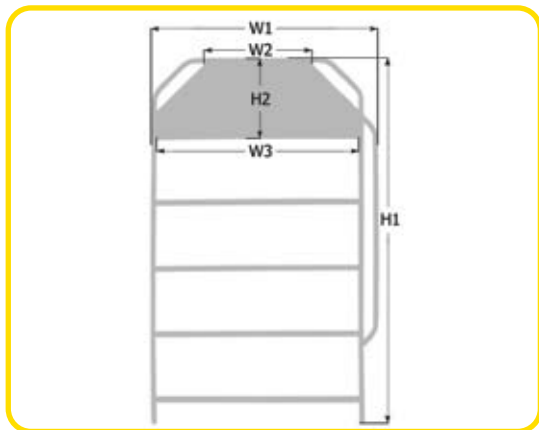

LARGE PIT BOARD

PART NUMBER	BGR251	BGR251BLA
MATERIAL	T6 ALUMINIUM	T6 ALUMINIUM
COLOUR	SILVER	BLACK
ROWS	4	4
HEIGHT (H1)	1290mm – 50.79"	1290mm – 50.79"
WIDTH (W1)	785mm – 30.91"	785mm – 30.91"
NAME PLATE HEIGHT (H2)	245mm	245mm
NAME PLATE TOP WIDTH (W2)	345mm	345mm
NAME PLATE BOTTOM WIDTH (W3)	700mm	700mm
NETT WEIGHT	1.80kg – 3.97lb	1.80kg – 3.97lb



The Large Pit Board Kits include a full set of Hi-Vis Numbers and a protective Carry Bag that features internal pockets to keep the Number Set organised.

The 38 piece number set for the Large Aluminium Pit Board includes numbers, letters, words and symbols. Available in a choice of Hi-Vis Green, Hi-Vis Orange, Hi-Vis Pink, White or Hi-Vis Yellow colours.

The bag is produced from Nylon fabric and features flaps to ensure the numbers do not fall out during transportation and a pair of removable and adjustable straps to make it easier to secure the bag to a pit wall.

The number sets and the bag can also be purchased separately.



LARGE PIT BOARD NUMBERS

PART NUMBER	BGR252G	BGR252O	BGR252P	BGR252	BGR252Y
MATERIAL	HIPS	HIPS	HIPS	HIPS	HIPS
COLOUR	GREEN	ORANGE	PINK	WHITE	YELLOW
HEIGHT	240mm – 9.44"	240mm – 9.44"	240mm – 9.44"	240mm – 9.44"	240mm – 9.44"
WIDTH	162mm – 6.38"	162mm – 6.38"	162mm – 6.38"	162mm – 6.38"	162mm – 6.38"
NETT WEIGHT	1.60kg – 3.53lb	1.60kg – 3.53lb	1.60kg – 3.53lb	1.60kg – 3.53lb	1.60kg – 3.53lb
NUMBERS	3x 0-9	3x 0-9	3x 0-9	3x 0-9	3x 0-9
LETTERS	1x P, L & T	1x P, L & T	1x P, L & T	1x P, L & T	1x P, L & T
WORDS	1x FUEL & IN	1x FUEL & IN	1x FUEL & IN	1x FUEL & IN	1x FUEL & IN
SYMBOLS	1x +, - & .	1x +, - & .	1x +, - & .	1x +, - & .	1x +, - & .

LARGE PIT BOARD KITS

PART NUMBER	SILVER BOARD, NUMBERS & BAG	BLACK BOARD, NUMBERS & BAG
	BGR250G (GREEN NUMBERS IN KIT)	BGR250BLA-G (GREEN NUMBERS IN KIT)
	BGR250O (ORANGE NUMBERS IN KIT)	BGR250BLA-O (ORANGE NUMBERS IN KIT)
	BGR250P (PINK NUMBERS IN KIT)	BGR250BLA-P (PINK NUMBERS IN KIT)
	BGR250 (WHITE NUMBERS IN KIT)	BGR250BLA-W (WHITE NUMBERS IN KIT)
	BGR250Y (YELLOW NUMBERS IN KIT)	BR250BLA-Y (YELLOW NUMBERS IN KIT)

LARGE PIT BOARD BAG

PART NUMBER	BGR253
MATERIAL	BLACK NYLON
FINISH	TEXTURED
HEIGHT	1310mm – 51.58"
WIDTH	820mm – 32.28"
NETT WEIGHT	5.40kg – 11.90lb



T: +44 (0) 1268 764411
 E: sales@bg-racing.co.uk
 W: www.bg-racing.co.uk





PIT STOP LOLLIPOP

Lollipop arrêt aux stands
Boxenstop Lollipop
Pit Stop Lecca Lecca
Señal de Mano de Parada en Boxes



Avoid missed pit boxes with the B-G Racing Pit Stop Lollipop, a simple, safe solution to signal drivers into the correct box.

A lightweight, telescopic fibreglass pole with foam grip handles allows for use in 2 different lengths and makes storage simple, whilst the durable ABS sign provided is drilled at both ends for use from either side of the box and is supplied blank on both sides allowing for complete customisation.

Additional ABS signs (BGR265SIGN) can be purchased separately.

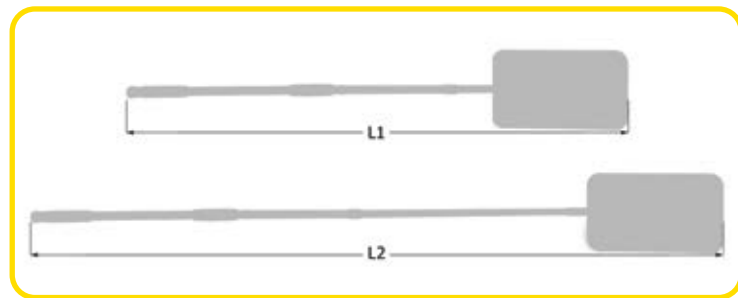

BGR265SIGN - ABS SIGN

TECHNICAL SPECIFICATIONS

PART NUMBER	BGR265
MATERIAL	FIBREGLASS, ALUMINIUM & ABS
FINISH	GLOSS & MATTE
COLOUR	BLACK
LENGTH (L1)	1610mm - 63.39"
LENGTH (L2)	2490mm - 98.03"
NETT WEIGHT	880g - 1.94lb

OPTIONS

PART NUMBER	BGR265SIGN
MATERIAL	ABS
HEIGHT	234mm - 9.21"
WIDTH	478mm - 18.82"
DEPTH	3mm - 0.18"
NETT WEIGHT	340g - 0.75lb



T: +44 (0) 1268 764411
E: sales@bg-racing.co.uk
W: www.bg-racing.co.uk

MECHANICS WORK MATS

Matelas pour mécano
 Mechanik Matte
 Tappetino da meccanico per ginocchia
 Esterilla mecánico

The B-G Racing Mechanics Work Mats provide a stable and comfortable platform perfect for working in the garage or pit lane. With 3 different options in the range, allowing users to either sit, kneel or lay comfortably when working on the vehicle. The perfect companion for those everyday tasks.

All mats are produced from a high quality 30mm thick heavy-duty EVA composition which is water and impact resistant and feature an integrated carry handle.

BGR400 Mechanics 3 in 1 Folding Work Mat features a 6-fold collapsible construction that can be manipulated to suit the user's requirements.

BGR401 Mechanics Kneeling Work Mat is small and compact, yet ideal for those quick tasks.

BGR402 Mechanics Work Mat is the largest in the range giving a greater surface area to lie on.



BGR400 – MECHANICS 3 IN 1 FOLDING WORK MAT



BGR402 – MECHANICS WORK MAT



BGR401 – MECHANICS KNEELING WORK MAT

TECHNICAL SPECIFICATIONS

PART NUMBER	BGR400	BGR401	BGR402
MATERIAL	HEAVY DUTY EVA FOAM	HEAVY DUTY EVA FOAM	HEAVY DUTY EVA FOAM
FINISH	TEXTURED	TEXTURED	TEXTURED
LENGTH	1210mm – 47.6"	450mm – 17.72"	1210mm – 47.6"
WIDTH	420mm – 16.53"	210mm – 8.26"	455mm – 17.91"
HEIGHT	30mm – 1.18"	30mm – 1.18"	30mm – 1.18"
FOLDED LENGTH	195mm – 7.68"	N/A	N/A
FOLDED HEIGHT	180mm – 7.08"	N/A	N/A
NETT WEIGHT	700g – 1.54lb	100g – 0.22lb	800g – 1.76lb



T: +44 (0) 1268 764411
 E: sales@bg-racing.co.uk
 W: www.bg-racing.co.uk



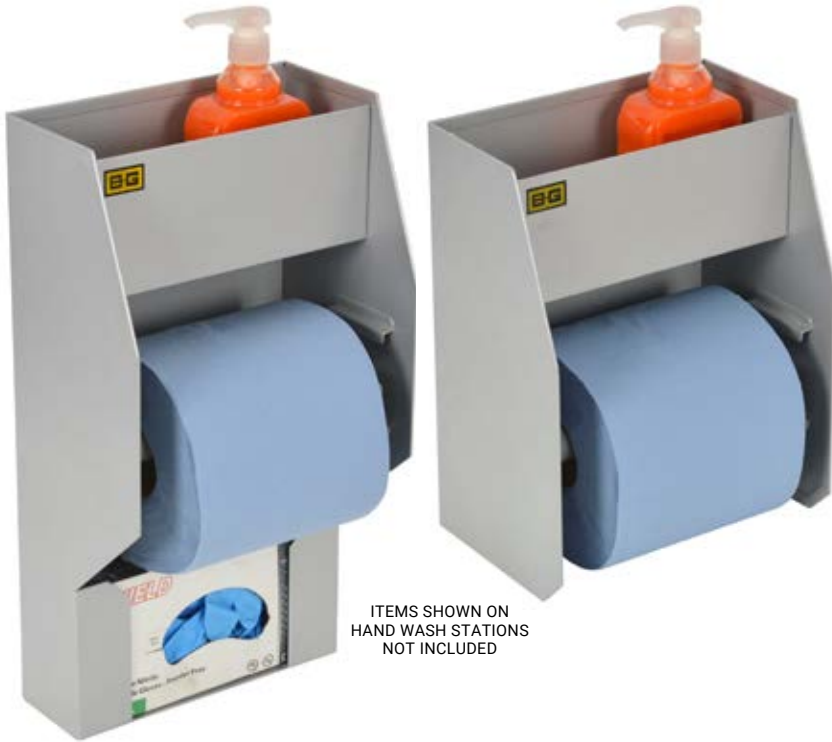

ITEMS SHOWN ON HAND WASH STATIONS NOT INCLUDED

HAND WASH STATIONS

Support Rouleaux Essuie-tout
Wandrollenhalter für Werkstatt
Mensola con portarotolo
Soporte para papel de limpieza

The Hand Wash Stations offer a neat and tidy solution for the storage of hand cleaner, paper towels and gloves whilst doubling as a dispenser for the workshop, truck or trailer.

An ideal solution to comply with new post Covid-19 requirements in the workplace to ensure employees and visitors clean their hands before and after making contact with different surfaces.

Manufactured from mild steel with a durable silver-grey powder coated finish, both Hand Wash Stations feature a paper towel roll holder, a storage shelf for cleaning/care products, and the larger version includes a dispenser for rubber gloves.

The Hand Wash Stations can be attached to the wall in a workshop, truck or trailer by their keyhole mounting points.

Compatible with the BGR278 Blue Paper Towel Roll or any other paper roll with a maximum width of 225mm and diameter of Ø180mm.



BG6050P - HAND WASH STATION



BG6052P - MINI HAND WASH STATION

TECHNICAL SPECIFICATIONS

PART NUMBER	BG6050P	BG6052P
MATERIAL	MILD STEEL	MILD STEEL
FINISH	POWDER COATED	POWDER COATED
HEIGHT (H)	485mm - 19.09"	337mm - 13.27"
WIDTH (W)	255mm - 10.04"	255mm - 10.04"
DEPTH (D)	171mm - 6.73"	171mm - 6.73"
LOADING CAPACITY	15.00kg - 33.07lb	15.00kg - 33.07lb
NETT WEIGHT	3.00kg - 6.61lb	2.20kg - 4.85lb



OPTIONS

PART NUMBER	PAPER TOWEL ROLL 6 PACK
BG6050P	BGR278
MATERIAL	PAPER 2PLY
HEIGHT	180mm - 7.09"
WIDTH	340mm - 13.39"
DEPTH	400 SHEETS
NETT WEIGHT	3.20kg - 7.05lb



T: +44 (0) 1268 764411
E: sales@bg-racing.co.uk
W: www.bg-racing.co.uk

TWO SHELF FLUID CABINETS

Armoire pour fluide
 Serviceprodukte Schrank
 Armadio per prodotti per la manutenzione
 Armario para líquido

The Two Shelf Fluid Cabinets offer a neat and tidy storage solution for multiple fluid bottles in your workshop, garage, truck, trailer or van.

Manufactured from mild steel with a durable silver-grey powder coated finish, the Two Shelf Fluid Cabinets are available in a Small or Large size.

The Large size is capable of storing various bottles, tins and pots; including the possibility of five 1 Litre bottles on the top shelf and a larger 5 Litre bottle on the bottom shelf.

The Small size is able to store up to five 1 Litre bottles on both the top and bottom shelf – a total of ten 1 litre bottles!

The Two Shelf Fluid Cabinets can be attached to the wall of a workshop, truck or trailer by its keyhole mounting points.



ITEMS SHOWN ON CABINETS NOT INCLUDED



BG6054P - LARGE TWO SHELF CABINET



BG6053P - SMALL TWO SHELF CABINET



TECHNICAL SPECIFICATIONS

PART NUMBER	BG6053P	BG6054P
MATERIAL	MILD STEEL	MILD STEEL
FINISH	POWDER COATED	POWDER COATED
HEIGHT (H)	420mm – 16.54"	480mm – 18.90"
WIDTH (W)	315mm – 12.40"	315mm – 12.40"
DEPTH (D)	150mm – 5.91"	170mm – 6.69"
LOADING CAPACITY	15.00kg – 33.07lb	15.00kg – 33.07lb
NETT WEIGHT	3.60kg – 7.94lb	4.70kg – 10.36lb



T: +44 (0) 1268 764411
 E: sales@bg-racing.co.uk
 W: www.bg-racing.co.uk





AEROSOL CAN SHELF

Support d'aérosol
Serviceprodukte Schrank
Porta Bombolette
Soporte para latas de aerosol



ITEMS SHOWN ON SHELF NOT INCLUDED

The Aerol Can Shelf offers a tidy storage solution for multiple aerosol cans in your workshop, garage, truck, trailer or van.

Manufactured from mild steel with a durable silver-grey powder coated finish, the shelf is able to store six standard sized cans.

The B-G Aerol Can Shelf can be attached to the wall of a workshop, truck or trailer by its keyhole mounting points.



TECHNICAL SPECIFICATIONS

PART NUMBER	BG6055P
MATERIAL	MILD STEEL
FINISH	POWDER COATED
HEIGHT (H)	170mm - 6.69"
WIDTH (W)	428mm - 16.85"
DEPTH (D)	100mm - 3.93"
LOADING CAPACITY	15.00kg - 33.07lb
NETT WEIGHT	1.60kg - 3.53lb

OIL BOTTLE SHELF

Armoire pour huiles
Ölschrank
Armadietto per olio
Armario para aceites

The Oil Bottle Shelf offers a neat storage solution for multiple oil/fluid bottles in your workshop, garage, truck, trailer or van.

Manufactured from mild steel with a durable silver-grey powder coated finish, the Oil Bottle Shelf is capable of storing up to ten 1 Litre bottles or three 5 Litre bottles, or a combination of each.

The Oil Bottle Shelf can be attached to the wall of a workshop, truck or trailer by its keyhole mounting points.



ITEMS SHOWN ON SHELF NOT INCLUDED

TECHNICAL SPECIFICATIONS

PART NUMBER	BG6056P
MATERIAL	MILD STEEL
FINISH	POWDER COATED
HEIGHT (H)	315mm - 12.40"
WIDTH (W)	645mm - 25.39"
DEPTH (D)	150mm - 5.90"
LOADING CAPACITY	15.00kg - 33.07lb
NETT WEIGHT	4.60kg - 10.14lb



T: +44 (0) 1268 764411
E: sales@bg-racing.co.uk
W: www.bg-racing.co.uk

UTILITY CABINET

Armoire murale atelier
 Werkstatt Hängeschrank
 Pensile per officina
 Armario para taller mecanico

The Utility Cabinet features a paper towel roll holder and a latching door which can double as a light duty work surface. It is suitable for storing a multitude of bottles, tins and pots, including large 5L or 1 Gallon oil containers, and can be hung in a workshop, truck or trailer by its keyhole mounting points.

Compatible with the BGR278 Blue Paper Towel Roll or any other paper roll with a maximum width of 290mm and diameter of Ø180mm (including Scott® Shop Towels).

TECHNICAL SPECIFICATIONS

PART NUMBER	BG6051P
MATERIAL	MILD STEEL
FINISH	POWDER COATED
HEIGHT (H)	702mm - 27.64"
WIDTH (W)	315mm - 12.40"
DEPTH (D)	171mm - 6.73"
LOADING CAPACITY	15.00kg - 33.07lb
NETT WEIGHT	6.40kg - 14.11lb

ITEMS SHOWN ON CABINET NOT INCLUDED



FLUID SPILL TRAYS

Bac de vidange
 Auffangwannen für Flüssigkeiten
 Vaschetta di raccolta dell'olio
 Bandeja Para Líquidos

An ideal solution to prevent unwanted fluid spills landing on the floor, these are perfectly suited to garage, workshop, factory or motorsport pit or paddock environments.

The low profile design allows for the Fluid Spill Trays to be easily slid underneath your machinery, vehicle or generator and catch any drips from reaching the floor. The trays can also be used for storing fluid drums, containers or bottles and provide strong resistance to various fluids, including; chemicals, fuel, oil, water and more.

Produced from durable polypropylene with a ribbed construction to provide additional strength, and completed in a smooth black finish.



FLUID SPILL TRAYS

PART NUMBER	BG5138	BG5139	BG5140	BG5141	BG5142
MATERIAL	POLYPROPYLENE	POLYPROPYLENE	POLYPROPYLENE	POLYPROPYLENE	POLYPROPYLENE
COLOUR	BLACK	BLACK	BLACK	BLACK	BLACK
LENGTH	1000mm - 39.37"	600mm - 23.62"	800mm - 31.50"	645mm - 25.39"	1200mm - 47.24"
WIDTH	400mm - 15.75"	600mm - 23.62"	800mm - 31.50"	495mm - 19.49"	550mm - 21.65"
HEIGHT	50mm - 1.96"	120mm - 4.72"	120mm - 4.72"	120mm - 4.72"	50mm - 1.96"
NETT WEIGHT	0.88kg - 1.94lb	1.28kg - 2.82lb	2.04kg - 4.49lb	1.14kg - 2.51lb	1.70kg - 3.74lb



T: +44 (0) 1268 764411
 E: sales@bg-racing.co.uk
 W: www.bg-racing.co.uk





3" CLUBMAN RACE SCALES

Balance Clubman 3"
3" Clubman Radlastwaagen
3" Kit Bilancia Clubman
Balanzas de Carrera 3"



An accurate scale system incorporating all of the features required for a team or driver to carry out a professional chassis set up. The Clubman Race Scales connect to the control pad using heavy-duty flexible cables.

The easy to use control pad displays the vehicle's four corner weights, the cross weights and percentages all at once which can be stored within the 20 slot internal memory. It also has the ability to calculate the vehicle's centre of gravity and the option to change the displays and configurations of the readings and features a low power consumption level with a rechargeable battery life of 40 hours.

A protective carry case is included to protect and transport the control pad, cables and mains power adaptor.



SERVICING AND CALIBRATION AVAILABLE

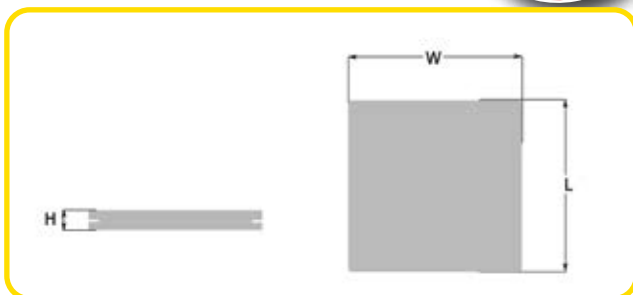

BGR327 - FLIGHT CASE

TECHNICAL SPECIFICATIONS

PART NUMBER	BGR325
MATERIAL	ALUMINIUM
SCALE PAD LENGTH (L)	381mm - 15.00"
SCALE PAD WIDTH (W)	381mm - 15.00"
SCALE PAD HEIGHT (H)	76.20mm - 3.00"
SCALE PAD NETT WEIGHT	9.80kg - 21.61lb PER SCALE PAD
SCALE PAD LOAD CAPACITY	680kg - 1496lb PER SCALE PAD
SCALE PAD POWER SUPPLY	POWERED BY THE CONTROL PAD AND CABLES
CONTROL PAD LENGTH	280mm - 11.02"
CONTROL PAD WIDTH	210mm - 8.26"
CONTROL PAD HEIGHT	76mm - 2.99"
CONTROL PAD NETT WEIGHT	1.20kg - 2.60lb
CABLE LENGTH	5.3m - 208.66"
CONTROL PAD POWER SUPPLY	220/240v - 12v ADAPTOR & RECHARGEABLE BATTERY
BATTERY LIFE	40 HOURS

FLIGHT CASE

PART NUMBER	BGR327
MATERIAL	ALUMINIUM & BIRCH PLY
HEIGHT	560mm - 22.04"
WIDTH	600mm - 23.62"
DEPTH	330mm - 12.99"
NETT WEIGHT	18.50kg - 40.78lb



T: +44 (0) 1268 764411
E: sales@bg-racing.co.uk
W: www.bg-racing.co.uk

3" WIRELESS RACE SCALES

Balance Wireless 3"
 3" Wireless Radlastwaagen
 3" Kit Bilancia Wireless
 Balanzas de Carrera 3"

The B-G Racing Wireless Race Scale pads are produced from aluminium with a ribbed construction for maximum strength and almost zero deflection. The wireless technology eliminates having cables all over the floor of your workshop and allows you to move around your race car with the wireless control pad in your hands.

The easy to use wireless control pad displays the vehicle's four corner weights, the axle weight, the cross weights and percentages all at once. The control pad display and configuration can be changed to suit the user's preference and features a low power consumption level.

A mains power adaptor is included for the control pad (with UK and EU plugs) in the event of replacement batteries not being immediately available. A protective carry case is included to protect and transport the control pad.



SERVICING AND CALIBRATION AVAILABLE

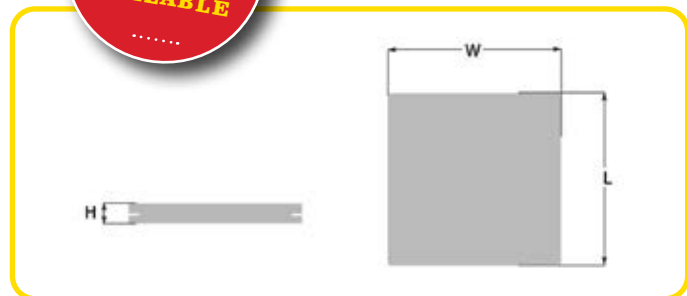

TECHNICAL SPECIFICATIONS

PART NUMBER	BGR330
MATERIAL	ALUMINIUM
SCALE PAD LENGTH (L)	381mm - 15.00"
SCALE PAD WIDTH (W)	381mm - 15.00"
SCALE PAD HEIGHT (H)	76.20mm - 3.00"
SCALE PAD NETT WEIGHT	9.80kg - 21.61lb PER SCALE PAD
SCALE PAD LOAD CAPACITY	680kg - 1496lb PER SCALE PAD
SCALE PAD POWER SUPPLY	4 x AA BATTERIES PER SCALE PAD
CONTROL PAD LENGTH	180mm - 7.08"
CONTROL PAD WIDTH	130mm - 5.11"
CONTROL PAD HEIGHT	40mm - 1.57"
CONTROL PAD NETT WEIGHT	600g - 1.30lb
CONTROL PAD POWER SUPPLY	6 x AA BATTERIES - 220/240V - 12v ADAPTOR



T: +44 (0) 1268 764411
 E: sales@bg-racing.co.uk
 W: www.bg-racing.co.uk





MODULAR SCALE PAD LEVELLING TRAYS

Plateaux de réglages pour balances
 Nivellier-Untersetzer
 Livellatore piatti
 Plataforma de nivelación

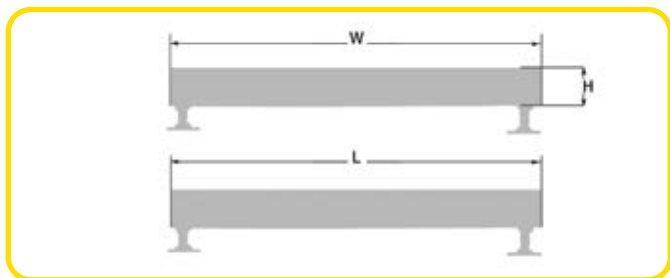

A key component of the B-G Racing modular scale system, these Scale Pad Levelling Trays are produced from mild steel with a powder coated finish and feature four high quality steel swivel feet with 75mm of adjustment to ensure complete accuracy. The feet can also be removed for ease of storage and transportation.

Suitable for use with 2.5" to 3" scale pads and designed for the B-G Racing Modular Roll Off Platforms to attach to.

The Scale Pad Levelling Trays are sold as a set of four.

The B-G Racing Levelling Foot Extension Kit has been designed for those uneven paddock floors where additional height is needed for one of the Levelling Trays. Offering 35mm of lift per foot, they can be used individually or joined together for increased height.



TECHNICAL SPECIFICATIONS

PART NUMBER	BGR352
MATERIAL	MILD STEEL
FINISH	POWDER COATED
LENGTH (L)	415mm – 16.33"
WIDTH (W)	415mm – 16.33"
HEIGHT (H)	70mm – 2.76"
NETT WEIGHT	5.40kg – 11.88lb PER TRAY
LOADING CAPACITY	680kg – 1496lb PER TRAY
SCALE SUITABILITY	2.50" to 3.00"

LEVELLING FOOT EXTENSION KIT

PART NUMBER	BGR356
MATERIAL	POLYOXYMETHYLENE
COLOUR	BLACK
NETT WEIGHT	500g – 1.10lb
PACK QUANTITY	4



T: +44 (0) 1268 764411
 E: sales@bg-racing.co.uk
 W: www.bg-racing.co.uk

MODULAR ROLL OFF PLATFORMS

Partie plane pour plateaux de réglages
 Roll-Off Verlängerung
 Pedana Roll-Offs
 Plataforma Roll-Off



The Modular Scale Pad Roll Off Platforms allow you to easily push your car on and off the scale pads to release bind from the suspension and tyres for more accurate corner weight readings.

Designed to simply attach to or be removed from the Modular Scale Pad Levelling Trays for ease of storage and transportation. The Roll Off Platforms are compatible with 2.5" to 3" scale pads.

Produced from mild steel with a durable silver grey powder coated finish and a brushed aluminium top plate. Featuring two high quality steel levelling feet with 75mm of adjustment per platform to ensure complete accuracy.

The Modular Roll Off Platforms are sold as a set of four.

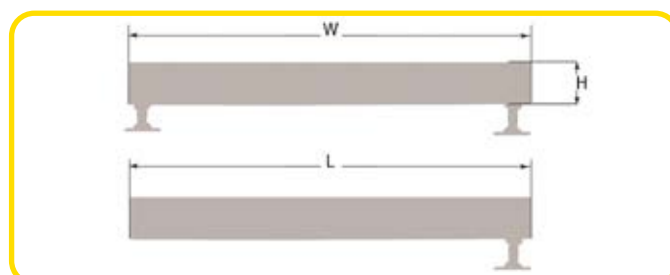

TECHNICAL SPECIFICATIONS

PART NUMBER	BGR353
MATERIAL	MILD STEEL & ALUMINIUM
FINISH	POWDER COATED & BRUSHED
LENGTH (L)	430mm - 16.93"
WIDTH (W)	390mm - 15.35"
HEIGHT (H)	72mm - 2.84"
NETT WEIGHT	7.20kg - 15.76lb PER PLATFORM
LOADING CAPACITY	680kg - 1496lb PER PLATFORM
SCALE SUITABILITY	2.50" to 3.00"



T: +44 (0) 1268 764411
 E: sales@bg-racing.co.uk
 W: www.bg-racing.co.uk





LEVELLING TRAY LEG EXTENSION KIT

Plateaux de réglages pied kit d'extension

Distanzfüße für Nivellieruntersetzer

Livellatore piatti - Kit di estensione piedi

Plataforma de nivelación - Kit de extensión pies



BGR360 - LEVELLING TRAYS WITH TALL LEG EXTENSION KIT



BGR361 - LEVELLING TRAYS WITH SHORT LEG EXTENSION KIT

Designed with strength, stability and convenience in mind, the Levelling Tray Leg Extension Kits bolt directly to a Modular Scale Pad Levelling Tray in order to raise your vehicle, and therefore your working area, to a much more comfortable position. Ideal to use in conjunction with a Two Post Lift, Scissor Lift or A-Frame Crane.

Manufactured from high-grade mild steel with a durable silver grey powder coated finish, the Tall Leg Extension Kit has been designed to be assembled and disassembled for ease of storage and transportation. The Short Leg Extension Kit utilises a fully welded construction.

Both of the Leg Extension Kits feature threaded bosses to accept the original adjustable levelling feet supplied with your Levelling Tray, allowing the same range of adjustment as standard.

Sold in a set of four.



BGR358 - TALL LEG EXTENSION KIT



BGR359 - SHORT LEG EXTENSION KIT



TECHNICAL SPECIFICATIONS

	TALL LEG EXTENSIONS	SHORT LEG EXTENSIONS	TALL LEGS & LEVELLING TRAYS	SHORT LEGS & LEVELLING TRAYS
PART NUMBER	BGR358	BGR359	BGR360	BGR361
MATERIAL	MILD STEEL	MILD STEEL	MILD STEEL	MILD STEEL
HEIGHT (H)	700mm - 27.56"	200mm - 7.87"	770mm - 30.31"	270mm - 10.63"
WIDTH (W1)	540mm - 21.26"	500mm - 19.69"	540mm - 21.26"	540mm - 21.26"
WIDTH (W2)	410mm - 16.14"	430mm - 16.93"	415mm - 16.33"	415mm - 16.33"
NETT WEIGHT (each)	10.50kg - 16.14lb	3.00kg - 6.61lb	13.15kg - 28.99lb	8.40kg - 18.52lb
LOADING CAPACITY	680kg - 1499.14lb	680kg - 1499.14lb	680kg - 1499.14lb	680kg - 1499.14lb

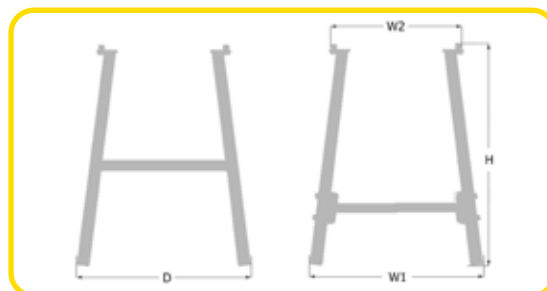

T: +44 (0) 1268 764411
 E: sales@bg-racing.co.uk
 W: www.bg-racing.co.uk

ALUMINIUM SCALE PAD LEVELLING TRAYS

Plateaux de réglage pour balance intégrée

Nivellier-Untersetzer

Livellatore piatti

Plataforma de nivelación

The Aluminium Scale Pad Levelling Trays will accept any 15" x 15" x 2.5" to 3" scale pads and feature high quality steel levelling feet with 75mm of adjustment.

The Aluminium Levelling Trays are engineered to make corner weight readings more accurate and repeatable.

Constructed from lightweight aluminium with a brushed finish, the compact design allows for easy storage and transportation.

Sold in a set of four.

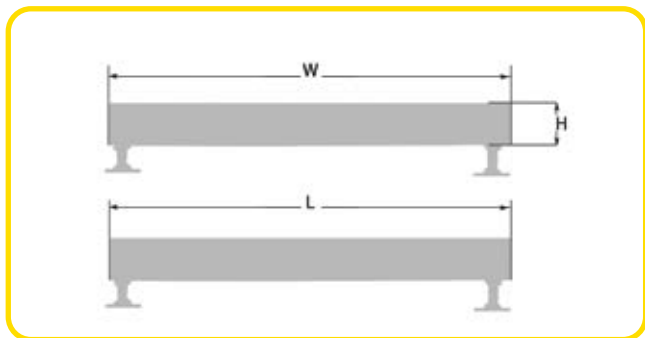

TECHNICAL SPECIFICATIONS

PART NUMBER	BGR351
MATERIAL	ALUMINIUM
FINISH	BRUSHED
LENGTH (L)	445mm - 17.50"
WIDTH (W)	445mm - 17.50"
HEIGHT (H)	50mm - 2.00"
NETT WEIGHT	5.50kg - 12.10lb PER TRAY
LOADING CAPACITY	680kg - 1496lb PER TRAY
SCALE SUITABILITY	2.50" to 3.00"

LEVELLING FOOT EXTENSION KIT

PART NUMBER	BGR356
MATERIAL	POLYOXYMETHYLENE
COLOUR	BLACK
NETT WEIGHT	500g - 1.10lb
PACK QUANTITY	4



T: +44 (0) 1268 764411
E: sales@bg-racing.co.uk
W: www.bg-racing.co.uk



HUB STANDS



Designed, developed and precision manufactured in the UK to the highest quality from 6061 T6 aluminium, the B-G Racing Hub Stands kit is the ultimate solution for vehicle set up and alignment.

This advanced and proven system replaces the vehicle wheel and tyre set, giving access directly to the hubs to carry out a complete suspension and alignment set up without needing to lift the vehicle, and eliminating the need to roll the vehicle on and off the scale pads to unload the suspension after adjustments. The changes occur in real time!

With B-G Racing Hub Stands, set up is faster and more precise than using a wheel and tyre set, with repeatable accurate measurements instead of the ever-changing figures caused by wheel and tyre variations.

Each base features a pair of high load, low resistance roller bearing wheels which allow the Hub Stands to respond with the vehicle suspension as changes are made. This keeps the suspension bind-free, which in turn makes the adjustment process quick and easy, showing the results of changes instantly.

The B-G Racing Hub Stands are height adjustable in 2mm increments to suit different tyre diameters and can be supplied with a variety of multi-drilled hub plates to suit different vehicle bolt patterns. The interchangeable plates are available in a wide range of configurations, including a selection of centre lock wheel hubs and any custom application.

Each set of Hub Stands includes a set of four aluminium Toe Sticks, precisely CNC machined in order to be bolted parallel to the hub face for stringing, or at the bottom of the Hub Stands base for measuring total toe. The Hub Stands are supplied with a set of eight 105mm Toe Stub Extensions designed to offset the Toe Stick away from the face of the hub to clear large brake calipers and grease caps. A set of four Stainless Steel Safety Plates are also included in the kit which are used to prevent the vehicle from rolling off the scale pads.

The B-G Racing Hub Stands are suitable for vehicles up to a weight of 2000kg (4400lb).



HUB STANDS KITS

The kit comprises of four CNC machined aluminium base assemblies and a set of your choice of interchangeable, multiple bolt pattern Hub Plates, four CNC machined aluminium Toe Sticks, eight 105mm Toe Stub Extensions and four stainless steel Safety Plates.

TECHNICAL SPECIFICATIONS

PART NUMBER	BGR9001	BGR9002	BGR9004	BGR9005	BGR9007	BGR9008	BGR9010
PCD	5 x 100mm – 3.93"	4 x 100mm – 3.93"	5 x 108mm – 4.25"	5 x 114.3mm – 4.50"	5 x 110mm – 4.33"	5 x 100mm – 3.93"	5 x 120mm – 4.72"
	5 x 108mm – 4.25"	4 x 108mm – 4.25"	5 x 114.3mm – 4.50"	5 x 120mm – 4.72"	5 x 114.3mm – 4.50"	5 x 112mm – 4.41"	5 x 115mm – 4.52"
	5 x 114.3mm – 4.50"	4 x 114.3mm – 4.50"	5 x 120mm – 4.72"	5 x 130mm – 5.12"	5 x 130mm – 5.12"	5 x 114.3mm – 4.50"	5 x 108mm – 4.25"
CENTRE BORE	71.1mm – 2.80"	70mm – 2.75"	76.2mm – 3.00"	88.9mm – 3.50"	72.6mm – 2.86"	73.6mm – 2.89"	76.2mm – 3.00"
NETT WEIGHT	32.00kg – 70.40lb	32.00kg – 70.40lb	32.00kg – 70.40lb	32.00kg – 70.40lb	32.00kg – 70.40lb	32.00kg – 70.40lb	32.00kg – 70.40lb
LOADING CAPACITY	2000kg – 4400lb	2000kg – 4400lb	2000kg – 4400lb	2000kg – 4400lb	2000kg – 4400lb	2000kg – 4400lb	2000kg – 4400lb

HUB STANDS VEHICLE SPECIFIC KITS

The kit comprises of four CNC machined aluminium base assemblies and a set of your choice of interchangeable vehicle specific Hub Plates, four CNC machined aluminium Toe Sticks, eight 105mm Toe Stub Extensions and four stainless steel Safety Plates.

TECHNICAL SPECIFICATIONS

PART NUMBER	BGR9000	BGR9003	BGR9006	BGR9009
SPECIFIC VEHICLE	BLANK	RADICAL SR3/SR8	PORSCHE 991 CUP	GINETTA G40/50/55
PCD	0 x 000mm – 0.00"	4 x 108mm – 4.25"	5 x 114.3mm – 4.50"	5 x 108mm – 4.25"
	0 x 000mm – 0.00"	HOLE Ø 20mm	5 x 120mm – 4.72"	5 x 110mm – 4.33"
	0 x 000mm – 0.00"		5 x 130mm – 5.12"	
CENTRE BORE	0.0mm – 0.00"	70mm – 2.75"	88.9mm – 3.50"	72.6mm – 2.86"
NETT WEIGHT	32.00kg – 70.40lb	32.00kg – 70.40lb	32.00kg – 70.40lb	32.00kg – 70.40lb
LOADING CAPACITY	2000kg – 4400lb	2000kg – 4400lb	2000kg – 4400lb	2000kg – 4400lb



CENTRE LOCKING WHEEL NUT COLLARS

Designed to allow cars with hubs utilising single centre locking wheel nuts to be used with Hub Stands. The collars are CNC machined in the UK from 6061 T6 aluminium and they are tailor made to match each wheel nut to ensure the Hub Stand centralises to provide repeatable measurements.

Bespoke fitments are available, please contact us to request a specification form.

The kits generally consist of four to eight collars depending upon vehicle specific details.



TECHNICAL SPECIFICATIONS

PART NUMBER	BGR9700	BGR9701	BGR9702	BGR9703	BGR9704	BGR9705	BGR9707	BGR9708
FITMENT	FERRARI F430 GT2	FERRARI 458 GT3/CHALLENGE	FERRARI 430 GT3/CHALLENGE	RADICAL SR3/SR8	BRITISH TOURING CAR (NGTC)	MCLAREN MP4-12C GT3	PORSCHE 964/ 993/996 & 997 CUP	PORSCHE 991.1/ 991.2 CUP CAR
ORDER WITH	BGR9004	BGR9004	BGR9004	BGR9003	BGR9005	BGR9004	BGR9005	BGR9006

PART NUMBER	BGR9709	BGR9710	BGR9711	BGR9712	BGR9713	BGR9714	BGR9715	BGR9716
FITMENT	GROUP 4 SPEC HUBS	LAMBORGHINI HURACAN TROFEO	LIGIER JSP3 LMP3	MCLAREN 650S GT3	TCR VW/AUDI HUB	MCLAREN 570S GT4	FERRARI 488 CHALLENGE	LAMBORGHINI HURACAN GT3
ORDER WITH	BGR9003	BGR9000	BGR9000	BGR9000	BGR9000	BGR9000	BGR9004	BGR9000



T: +44 (0) 1268 764411
E: sales@bg-racing.co.uk
W: www.bg-racing.co.uk





ADDITIONAL HUB STAND PLATES

Allows for one set of Hub Stand bases to be used on multiple vehicles with different PCD's. Consists of four plates.

TECHNICAL SPECIFICATIONS

PART NUMBER	BGR9201	BGR9202	BGR9204	BGR9205	BGR9207	BGR9208	BGR9210
PCD	5 x 100mm – 3.93"	4 x 100mm – 3.93"	5 x 108mm – 4.25"	5 x 114.3mm – 4.50"	5 x 110mm – 4.33"	5 x 100mm – 3.93"	5 x 120mm – 4.72"
	5 x 108mm – 4.25"	4 x 108mm – 4.25"	5 x 114.3mm – 4.50"	5 x 120mm – 4.72"	5 x 114.3mm – 4.50"	5 x 112mm – 4.41"	5 x 115mm – 4.52"
	5 x 114.3mm – 4.50"	4 x 114.3mm – 4.50"	5 x 120mm – 4.72"	5 x 130mm – 5.12"	5 x 130mm – 5.12"	5 x 114.3mm – 4.50"	5 x 108mm – 4.25"
CENTRE BORE	71.1mm – 2.80"	70mm – 2.75"	76.2mm – 3.00"	88.9mm – 3.50"	72.6mm – 2.86"	73.6mm – 2.89"	76.2mm – 3.00"

HUB STAND PRO KIT

Includes one complete Hub Stand kit, plus a Toe Stick Pro Kit and Flight Carry Case.

TECHNICAL SPECIFICATIONS

PART NUMBER	BGR9301	BGR9302	BGR9304	BGR9305	BGR9307	BGR9308	BGR9310
PCD	5 x 100mm – 3.93"	4 x 100mm – 3.93"	5 x 108mm – 4.25"	5 x 114.3mm – 4.50"	5 x 110mm – 4.33"	5 x 100mm – 3.93"	5 x 120mm – 4.72"
	5 x 108mm – 4.25"	4 x 108mm – 4.25"	5 x 114.3mm – 4.50"	5 x 120mm – 4.72"	5 x 114.3mm – 4.50"	5 x 112mm – 4.41"	5 x 115mm – 4.52"
	5 x 114.3mm – 4.50"	4 x 114.3mm – 4.50"	5 x 120mm – 4.72"	5 x 130mm – 5.12"	5 x 130mm – 5.12"	5 x 114.3mm – 4.50"	5 x 108mm – 4.25"
CENTRE BORE	71.1mm – 2.80"	70mm – 2.75"	76.2mm – 3.00"	88.9mm – 3.50"	72.6mm – 2.86"	73.6mm – 2.89"	76.2mm – 3.00"
NETT WEIGHT	66.00kg – 145.20lb	66.00kg – 145.20lb	66.00kg – 145.20lb	66.00kg – 145.20lb	66.00kg – 145.20lb	66.00kg – 145.20lb	66.00kg – 145.20lb
LOADING CAPACITY	2000kg – 4400lb	2000kg – 4400lb	2000kg – 4400lb	2000kg – 4400lb	2000kg – 4400lb	2000kg – 4400lb	2000kg – 4400lb

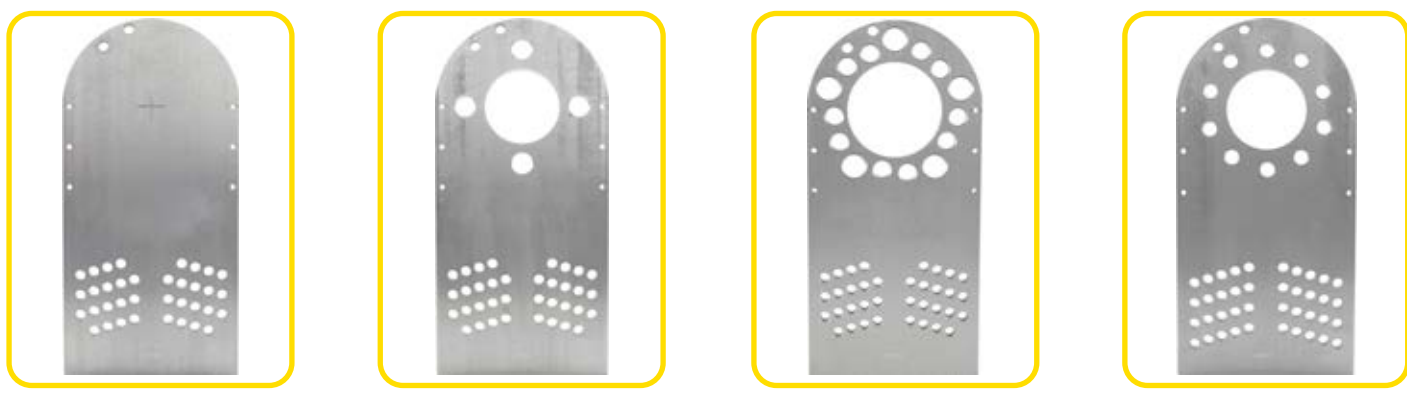

VEHICLE SPECIFIC PLATES

TECHNICAL SPECIFICATIONS

PART NUMBER	BGR9200	BGR9203	BGR9206	BGR9209
SPECIFIC VEHICLE	BLANK	RADICAL SR3/SR8	PORSCHE 991 CUP	GINETTA G40/50/55
PCD	0 x 000mm – 0.00"	4 x 108mm – 4.25"	5 x 114.3mm – 4.50"	5 x 108mm – 4.25"
	0 x 000mm – 0.00"	HOLE Ø 20mm	5 x 120mm – 4.72"	5 x 110mm – 4.33"
	0 x 000mm – 0.00"		5 x 130mm – 5.12"	
CENTRE BORE	0.0mm – 0.00"	70mm – 2.75"	88.9mm – 3.50"	72.6mm – 2.86"



SPARES

	TOE STICKS	TOE STUBS	SAFETY PLATES	FLIGHT CARRY CASE
PART NUMBER	BGR9600	BGR9650	BGR9850	BGR9900
MATERIAL	ALUMINIUM	ALUMINIUM	STAINLESS STEEL	PLY & ALUMINIUM
NETT WEIGHT	2.40kg – 5.28lb	1.00kg – 2.20lb	9.00kg – 19.80lb	22.60kg – 49.72lb



T: +44 (0) 1268 764411
 E: sales@bg-racing.co.uk
 W: www.bg-racing.co.uk

HUB STANDS TOE STICK PRO

Hub Stands - Barres Alinement

Hub Stands - Spurmessgerät

Hub Stands - barre di misurazione angoli di convergenza

Hub Stands - Pro Sistema De Alineación

The Hub Stands Toe Stick Pro Kit is a revamped version of the existing Toe Stick and Toe Stub set up which features a pair of sliding, laser-etched measurement scales that make reading the values quick and simple in conjunction with the String Lines.

Designed for use on the B-G Racing Hub Stands, the Pro Kit has been manufactured to work with wheel diameters ranging from 12" to 22" thanks to the sliding Measurement Scales that are held securely in place with a pair of knurled thumb screws included with the kit.

Finished with a black anodised coating, the Toe Stick Pro Kit also includes a set of eight 105mm aluminium Toe Stubs to offset the Toe Stick away from the face of the hub to clear large brake calipers and grease caps and Steel Plates which mount in the centre line of the hub for use with our range of magnetic camber measurement equipment.



HUB STAND NOT INCLUDED

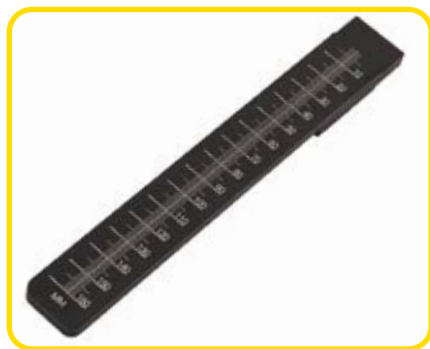

GAUGE NOT INCLUDED



TECHNICAL SPECIFICATIONS

PART NUMBER	BGR9500	BGR9501
MATERIAL	ALUMINIUM & STEEL	ALUMINIUM & STEEL
FINISH	ANODISED & BRUSHED	ANODISED & BRUSHED
COLOUR	BLACK & SILVER	BLACK & SILVER
QUANTITY	SET OF 2	SET OF 4
RULER RESOLUTION	1mm	1mm
WHEEL DIAMETER	12" TO 22"	12" TO 22"
NETT WEIGHT	2.20kg – 4.85lb	4.40kg – 9.70lb



T: +44 (0) 1268 764411
 E: sales@bg-racing.co.uk
 W: www.bg-racing.co.uk



DIGITAL DUAL AXIS ANGLE GAUGE

Niveau digital de carrossage et bulle de chasse
 Digitales Sturz – und Nachlaufmessgerät
 Indicatore digitale caster/camber con custodia
 Nivel digital



The compact gauge can be used to measure absolute and relative angles to 0.1° accuracy in 0.02° increments in both single and dual axis modes.

Featuring a large back lit LCD screen, hold button to freeze display, a programmable audio buzzer, auto power off and V shaped multiple magnetic sides for easy mounting.

Low power consumption with a rechargeable battery life of 40 hours. USB and mains charger included in kit.

A Hub Stands Mounting Kit (BGR305) is available separately to easily mount the unit and measure camber angles. The Mounting Kit is machined from billet aluminium with a durable bright silver anodised finish.



TECHNICAL SPECIFICATIONS

PART NUMBER	BGR304
ACCURACY	0.1° (1/10 DEGREE)
RESOLUTION	0.02°
POWER SUPPLY	RECHARGEABLE LITHIUM-ION
OPERATING BATTERY LIFE	40 HOURS
STANDBY BATTERY LIFE	4000 HOURS
HEIGHT (H)	70mm - 2.75"
WIDTH (W)	70mm - 2.75"
DEPTH (D)	23mm - 0.90"
NETT WEIGHT	120g - 0.26lb

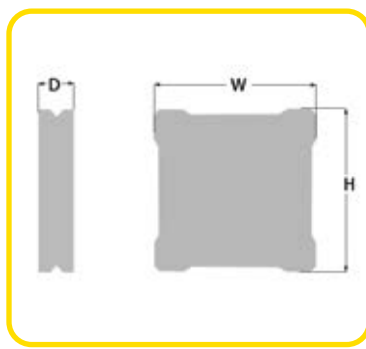

MOUNTING KIT

PART NUMBER	BGR305
MATERIAL	ALUMINIUM
FINISH	BRIGHT SILVER ANODISED
HEIGHT	76mm - 2.99"
WIDTH	25mm - 0.98"
DEPTH	32.5mm - 1.27"
NETT WEIGHT	80g - 0.18lb



T: +44 (0) 1268 764411
 E: sales@bg-racing.co.uk
 W: www.bg-racing.co.uk

BILLET DIGITAL CAMBER / CASTOR GAUGE

Niveau à bulle pour carrossage, pivot et chasse avec adaptateur magnetique

Sturz- und Nachlaufmessgerät mit Magnetadapter

Livella caster/camber con constodia e attacco magnetico

Medidor de camber con adaptador



Precision CNC machined billet alloy frame, the B-G Racing Digital Camber / Castor Gauge utilises the B-G Racing Digital Dual Axis Angle Gauge to accurately measure camber and castor to 0.1° repeatable accuracy, clearly displayed on the large 0.02° resolution backlit LCD screen. Suitable for either left or right handed users, with auto power-off and rechargeable lithium-ion battery giving up to 40 hours operation.

Additionally, the B-G Racing Digital Dual Axis Angle Gauge can be removed and used separately as a digital angle finder for suspension, strut, pinion, spoiler angles and many other applications.

Complete with protective carry case and magnetic adaptor for quick and easy hub mounting.

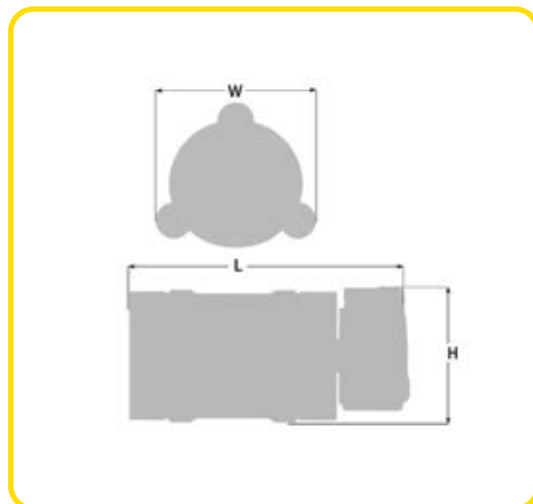

TECHNICAL SPECIFICATIONS

PART NUMBER	BGR306
MATERIAL	BILLET ALUMINIUM
FINISH	BLACK ANODISED
CAMBER MEASURING RANGE	-90° to +90°
CASTOR MEASURING RANGE	-90° to +90°
ACCURACY	0.1° (1/10 DEGREE)
POWER SUPPLY	RECHARGEABLE LITHIUM-ION
OPERATING BATTERY LIFE	40 HOURS
STANDBY BATTERY LIFE	4000 HOURS
LENGTH (L)	143mm - 5.62"
WIDTH (W)	68mm - 2.67"
HEIGHT (H)	65mm - 2.55"
NETT WEIGHT	560g - 1.23lb



T: +44 (0) 1268 764411
E: sales@bg-racing.co.uk
W: www.bg-racing.co.uk



BILLET CAMBER / CASTOR BUBBLE GAUGE



Niveau à bulles avec adaptateur magnetique
 Sturz- und Nachlaufmessgerät mit Magnet adapter
 Livella caster/camber con custodia e attacco magnetico
 Medidor de camber con adaptador

Precision CNC machined billet alloy casing, the B-G Racing Camber / Castor Bubble Gauge accurately measures to +/- 6 degrees camber and -4 to +12 degrees castor, clearly displayed on separate positive and negative vials.

A stepped design ensures all vials are aligned to the hub centre line.

Finished in a black anodised coating with laser etched detailing, protective foam lined carry case and magnetic adaptor included.

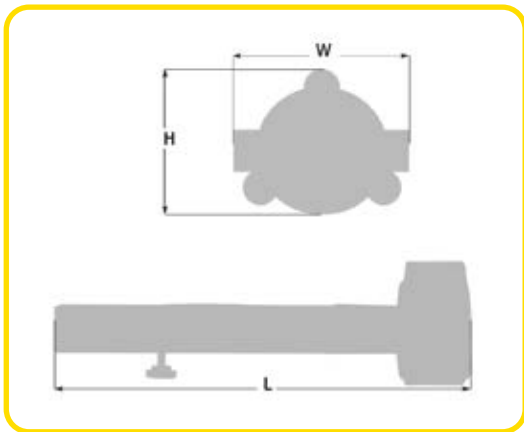

TECHNICAL SPECIFICATIONS

PART NUMBER	BGR303
MATERIAL	BILLET ALUMINIUM
FINISH	BLACK ANODISED
CAMBER MEASURING RANGE	-6° to +6°
CASTOR MEASURING RANGE	-4° to +12°
LENGTH (L)	220mm - 8.66"
WIDTH (W)	77mm - 3.03"
HEIGHT (H)	65mm - 2.55"
NETT WEIGHT	500g - 1.10lb



T: +44 (0) 1268 764411
 E: sales@bg-racing.co.uk
 W: www.bg-racing.co.uk

ALUMINIUM CAMBER FRAME WITH DIGITAL DUAL AXIS ANGLE GAUGE

Équerre pour mesurer le carrossage avec le niveau digital
 Alurahmen mit Digitales Sturzlaufmessgerät

Livella camber e caster

Medidor de camber digital con adaptador para llantas

The Aluminium Camber Frame is produced with a durable black powder coated finish and is supplied with the Digital Dual Axis Angle Gauge (BGR304) offering quick and simple camber measurement for left or right handed users on vehicles with wheel diameters up to 20".

The Digital Dual Axis Angle Gauge reads camber and castor from -90 to +90 degrees and is removable for standalone use.

The Aluminium Camber Frame can also be purchased separately without the Digital Dual Axis Angle Gauge (BGR307FR).

A protective carry bag is available to keep the Aluminium Camber Frame and Digital Dual Axis Angle Gauge protected during storage and transportation (BGR307BAG).

The 3 Pin Adaptor (BGR309) is available for additional wheel rim support.

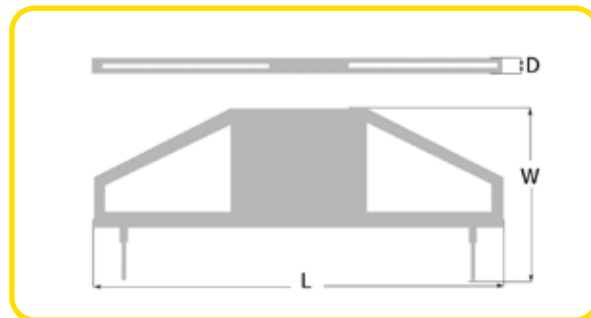

TECHNICAL SPECIFICATIONS

PART NUMBER	BGR307	BGR307FR	BGR307BAG	BGR309
MATERIAL	ALUMINIUM	ALUMINIUM	NYLON & FOAM	ALUMINIUM
FINISH	POWDER COATED	POWDER COATED	N/A	POWDER COATED
ACCURACY	0.1° (1/10 degree)	N/A	N/A	N/A
RESOLUTION	0.02°	N/A	N/A	N/A
POWER SUPPLY	RECHARGEABLE LITHIUM-ION	N/A	N/A	N/A
OPERATING BATTERY LIFE	40 HOURS	N/A	N/A	N/A
STANDBY BATTERY LIFE	4000 HOURS	N/A	N/A	N/A
LENGTH (L)	570mm - 22.44"	570mm - 22.44"	600mm - 23.62"	75mm - 2.95"
WIDTH (W)	255mm - 10.04"	255mm - 10.04"	280mm - 11.02"	450mm - 17.72"
DEPTH (D)	28mm - 1.10"	28mm - 1.10"	35mm - 1.37"	55mm - 2.17"
NETT WEIGHT	860g - 1.90lb	740g - 1.63lb	420g - 0.93lb	500g - 1.10lb



BGR309 - 3 PIN ADAPTOR



T: +44 (0) 1268 764411
 E: sales@bg-racing.co.uk
 W: www.bg-racing.co.uk





ALUMINIUM MAGNETIC TOE MEASURING PLATES

Instrument de mesure de l'alignement
 Spur Mess- und Einstellgerät
 Strumento di Allineamento Delle Ruote
 Alineado de ruedas tablero



Measuring toe is quick and simple with the Aluminium Toe Plates. Simply rest one of these high-strength, lightweight plates flat against the tyre on each side of the vehicle and use the 5 metre magnetic tapes provided to accurately measure the toe.

Kicked-out bottoms hold the plates flat against the wheels, whilst the tapes feature strong magnetic ends which attract to the slots to securely hold them in place whilst working.

Produced from aluminium with a durable black powder coated finish.

A protective carry bag is available separately to keep the Toe Measuring Plates and Magnetic Tapes protected during storage and transportation (BGR308BAG).



BGR308TAPES – MEASURING TAPES (PAIR)



BGR308BAG – PROTECTIVE CARRY BAG

TECHNICAL SPECIFICATIONS

PART NUMBER	BGR308	BGR308BAG	BGR308TAPES
MATERIAL	ALUMINIUM	NYLON	N/A
FINISH	BLACK POWDER COATED	N/A	N/A
LENGTH (L)	700mm – 27.56"	740mm – 29.13"	N/A
DEPTH (D)	40mm – 1.58"	70mm – 2.75"	N/A
HEIGHT (H)	292mm – 11.50"	30mm – 1.18"	N/A
TAPE MEASURE	5m – 16.4ft LENGTH	N/A	5m – 16.4ft LENGTH
NETT WEIGHT	3.90kg – 8.60lb	800g – 1.76lb	594g – 1.30lb



T: +44 (0) 1268 764411
 E: sales@bg-racing.co.uk
 W: www.bg-racing.co.uk

360 DEGREE LASER LEVELLING KIT

Kit Niveau Laser
 Radlastwaagen-Niveliergerat
 Livella laser
 Kit de nivelación láser



The 360 Degree Laser Levelling Kit is the fastest and most accurate way to check and adjust scale pads, levelling trays, roll-off platforms, and flat patches before use.

Ensuring your working area is level is an important step to make sure corner weight readings and alignment settings are consistently correct, and the 360-degree Levelling Laser coupled with the folding flags makes the process quick, easy, and repeatable.

The clear black on white incremental markings and scale pad corner to corner footprint of the flags removes the guesswork from the levelling process, whilst the bright green Levelling Laser requires absolutely no adjustment before use – it works straight out of the case. Simply place upright at a height matching your platforms or scale pads, unlock the levelling mechanism and switch on the laser for a perfectly level target beam.

Supplied in a protective carry case and with the option of a tripod (BG5155) for working with our taller Levelling Tray Leg Extension Kits, the 360 Degree Laser Levelling Kit brings accuracy and convenience to any set up.



TECHNICAL SPECIFICATIONS

PART NUMBER	BGR311
MATERIAL	ALUMINIUM & MILD STEEL
COLOUR	WHITE, GREEN & BLACK
FLAG WIDTH	355mm - 13.98"
FLAG HEIGHT	100mm - 3.93"
LASER WAVE LENGTH	510 +/- 5nm (GREEN)
LASER CLASS	CLASS 2 (IEC/EN60825-1/2014)
LASER ACCURACY	+/- 2mm OVER 10m
LASER IP RATING	IP54
MAXIMUM POWER OUTPUT	LESS THAN / EQUAL TO 1mW
NETT WEIGHT	5.18kg - 11.42lb
POWER SUPPLY	4 x AA BATTERIES
BATTERY LIFE	APPROX 6 HOURS



T: +44 (0) 1268 764411
 E: sales@bg-racing.co.uk
 W: www.bg-racing.co.uk



TURN PLATES

Plateaux tournants
Drehplatten
Piatto meccanico rotante
Platos Giratorios



Constructed from lightweight aluminium, these Turn Plates are ideal for measuring castor, camber and kingpin inclination angles and can be placed directly on top of scale pads.

The Turn Plates feature ball bearings to enable free floating movement and ensure they do not bind, allowing for 25 degrees of rotation.

The laser etched dial can be zeroed when a vehicle is on the Turn Plates.

Sold as a set of two.

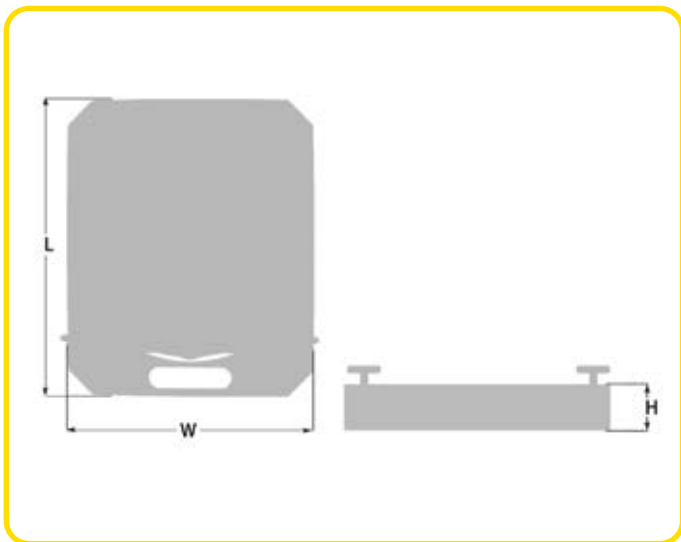

TECHNICAL SPECIFICATIONS

PART NUMBER	BGR301
MATERIAL	ALUMINIUM
FINISH	BLACK ANODISED
LENGTH (L)	445mm - 17.52"
WIDTH (W)	380mm - 14.96"
HEIGHT (H)	26mm - 1.02"
NETT WEIGHT	5.20kg - 11.46lb PER TURN PLATE
LOADING CAPACITY	450kg - 990lb PER TURN PLATE



T: +44 (0) 1268 764411
E: sales@bg-racing.co.uk
W: www.bg-racing.co.uk

EZ SWEEP CASTOR SLIP PLATES

- EZ Sweep Plaques réglage
- EZ Sweep Drehplatten
- EZ Sweep piatto meccanico rotante
- EZ Sweep Platos Oscilantes

Ultra-thin EZ Sweep Castor Slip Plates allow you to drive your vehicle straight on, eliminating the need for any ramps or vehicle lifting.

With 20 degrees of rotation, they are ideal for measuring castor, camber and kingpin inclination angles.

This product has been engineered with a PTFE coated surface enabling it to slip, eliminating the necessity of grease and bearings.

Robustly constructed with a stainless steel base, this allows for these Slip Plates to be placed on the floor or directly on top of scale pads.

Sold as a set of two.

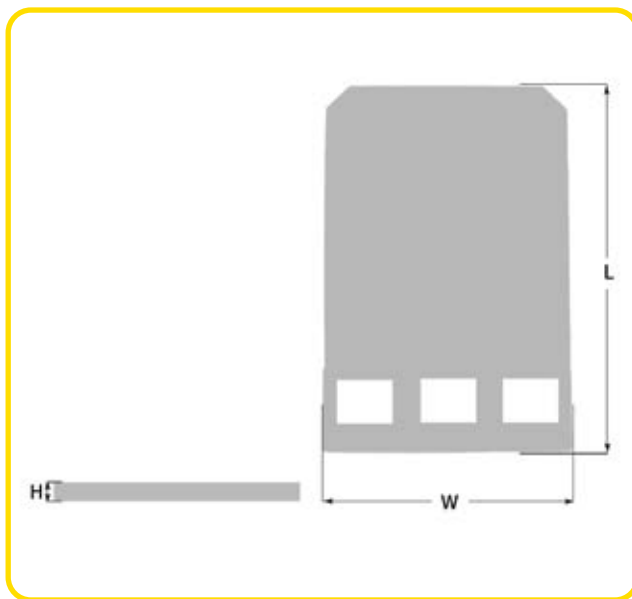

TECHNICAL SPECIFICATIONS

PART NUMBER	BGR302
MATERIAL	ALUMINIUM & STAINLESS STEEL
FINISH	BLACK ANODISED
LENGTH (L)	395mm - 15.55"
WIDTH (W)	255mm - 10.04"
HEIGHT (H)	5mm - 0.19"
NETT WEIGHT	1.80kg - 4.08lb PER SLIP PLATE
LOADING CAPACITY	680kg - 1496lb PER SLIP PLATE



T: +44 (0) 1268 764411
 E: sales@bg-racing.co.uk
 W: www.bg-racing.co.uk





STRING LINES



B-G String Lines are the easiest and most accurate way to achieve four wheel alignment. The frames are fully adjustable to allow fitment to a wide range of cars and attaches to the vehicle using the hooking feet which are interchangeable with all of the tubes in the kit.

The string bars have a number of pre-machined grooves for the strings to locate in and a pair of extension bars making the B-G String Lines suitable for cars of different widths.

The B-G String Lines kit consists of front and rear multi-adjustable boss units manufactured from high-grade mild steel with a durable silver grey powder coated finish, hooking feet manufactured from high-grade mild steel with a polyurethane coating, silver zinc plated various length tubes, string bars machined from aluminium with a bright silver anodised coating and plastic String Line Reels (BGR201), which are also available separately.

The kit can be used in conjunction with Hub Stands, Clubman Race Scales and Scale Pad Levelling Trays to achieve the ultimate vehicle set up.

A black nylon Carry Bag (BGR203) is available separately to store and transport the complete kit with ease.



BGR203 - CARRY BAG

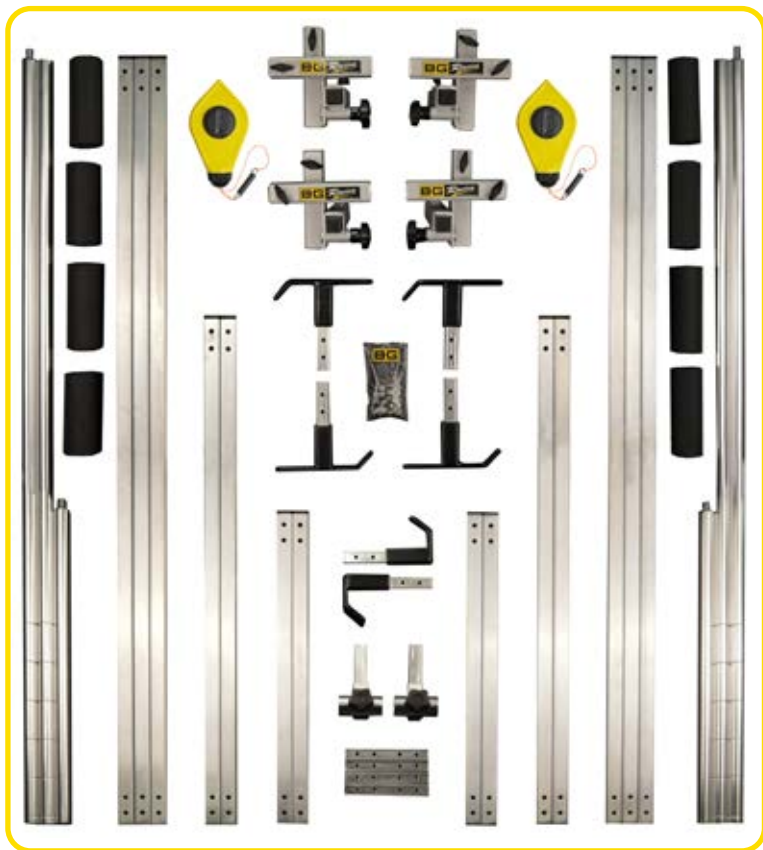

The tubes come in three different lengths and can be joined using the four tube connectors provided.

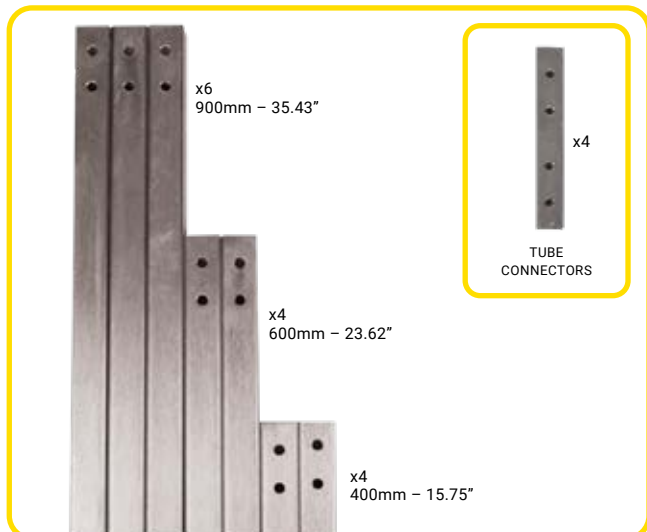

Three types of feet that fit easily to all three length tubes. One type is double sided to give additional options when attaching the frames to the vehicles.



Four aluminium stringing bars and two extension bars with an anodised finish. The stringing bars feature machined grooves that the string lines locate into to ensure accurate positioning.

Four powder coated boss units that are fully adjustable to give options to suit various vehicles and applications.

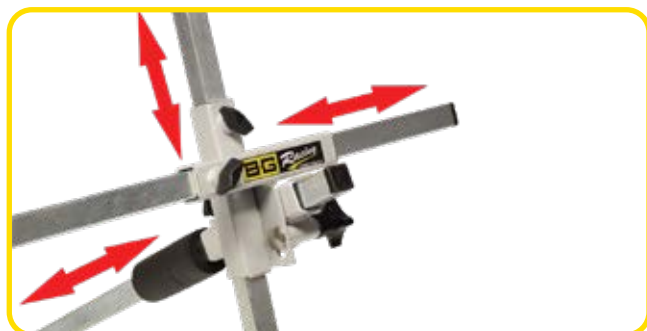

String line reels make the stringing process simple and also offer a neat storage solution to keep the string clean and tidy when not in use.



TECHNICAL SPECIFICATIONS

PART NUMBER	BGR200	BGR203	BGR201
MATERIAL	MILD STEEL	NYLON	PLASTIC
FINISH	POWDER COATED, ZINC PLATED & ANODISED	TEXTURED	N/A
NETT WEIGHT	16.10kg - 35.49lb	2.10kg - 4.63lb	140g - 0.31lb



T: +44 (0) 1268 764411
 E: sales@bg-racing.co.uk
 W: www.bg-racing.co.uk



BUMP STEER GAUGE

Jauge variation de parallélisme
 Bumpsteer Messgerät
 BumpSteer Gauge
 Bump steer



Bump steer is the involuntary change in toe/steering angle during the compression and rebound of vehicle suspension travel.

The Bump Steer Gauge allows the user to measure and correct bump steer, therefore greatly optimising suspension behaviour and chassis characteristics.

The Bump Steer Gauge features an aluminium multi-drilled PCD plate with measurement scale, a single digital dial indicator which measures in both millimetres and inches, and a precision roller bearing which couples with the hinged base to follow the arc of suspension travel during use for simple, accurate measurement.

The height adjustable frame makes the Bump Steer Gauge versatile, whilst acting as a lock when folded away for safe, easy flat-pack transport.

Manufactured from high-grade mild steel with a durable silver-grey powder coated finish, the Bump Steer Gauge is a must-have piece of chassis set up equipment.

An optional black nylon carry bag (BGR310BAG) is available to keep your Bump Steer Gauge protected during storage and transportation.



BGR310BAG - CARRY BAG

TECHNICAL SPECIFICATIONS

PART NUMBER	BGR310	BGR310BAG
MATERIAL	ALUMINIUM & MILD STEEL	NYLON
FINISH	ANODISED & POWDER COATED	SMOOTH
HEIGHT	485mm - 19.09"	570mm - 22.44"
WIDTH	255mm - 10.04"	520mm - 20.47"
DEPTH	171mm - 6.73"	110mm - 4.33"
FOLDED HEIGHT	85mm - 3.34"	N/A
FOLDED WIDTH	510mm - 20.08"	N/A
FOLDED DEPTH	540mm - 21.26"	N/A
ACCURACY	0.1mm - 0.003"	N/A
RESOLUTION	0.01mm - 0.0005"	N/A
NETT WEIGHT	4.10kg - 9.04lb	1.00kg - 2.20 lb



T: +44 (0) 1268 764411
 E: sales@bg-racing.co.uk
 W: www.bg-racing.co.uk

TYRE PRESSURE GAUGE

Manomètre pression pneu

Luftdruckprüfer

Manometro pressione pneumatici

Manometro Presion Analogico

The 2.5" Tyre Pressure Gauge is manufactured in the USA and rigorously tested to provide repeatable and accurate readings.

Featuring a dual unit face, measuring from 0 to 60 Psi and 0 to 4 Bar, this gauge will be suitable for a wide range of users, and it's fitted with a quick-bleed button valve on the handle to make fast pressure adjustments when required.

The 2.5" Tyre Pressure Gauge handle is CNC machined from aluminium and fitted with a flexible 457mm (18") length black hose, completed with a ball foot chuck for quick and easy attachment to the tyre valve.

A rubber bumper around the head of the gauge helps to protect the dial face from damage.



TECHNICAL SPECIFICATIONS

PART NUMBER	BGR515
MATERIAL	ALUMINIUM
HEIGHT	127mm - 5.00"
WIDTH	76.2mm - 3.00"
DEPTH	38.1mm - 1.50"
HOSE LENGTH	457mm - 18.00"
PRESSURE RANGE	0 to 60 PSI / 0 to 4 BAR
ACCURACY	0.5 PSI / 0.03 BAR
RESOLUTION	1 Psi / 0.1 Bar
NETT WEIGHT	0.27kg - 0.59lb



T: +44 (0) 1268 764411
 E: sales@bg-racing.co.uk
 W: www.bg-racing.co.uk





INFRARED THERMOMETER GUN

Pyromètre infrarouge
Infrarot Laser Temperaturmessgerät
Termometro a infrarossi con puntatore laser
Pyrometro laser

The Infrared Thermometer Gun is both compact and lightweight featuring a laser sight, Celsius/Fahrenheit selection and adjustable emissivity, it's a fast and highly accurate pyrometer giving instant non-contact surface temperature readings from -50 to 800°C (-58 to 1472°F).

The Infrared Thermometer Gun displays minimum, maximum and average temperatures on the backlit display in 0.1 degree increments ideal for measuring engine, track, radiator temperatures etc.

Multiple mode functions including 'Temperate Difference', 'High Temperature Alarm', 'Low Temperature Alarm' and 'Data Storage' for recording 12 surface temperatures with instant recall facility.

A built in low battery indicator and auto power-off help preserve the 9V battery included with the pyrometer, and a rubber coating on the plastic body aids grip and usability whilst offering a premium feel in the hand.

Supplied in a hard shell, foam lined carry case for protection during storage and transportation.

TECHNICAL SPECIFICATIONS

PART NUMBER	BGR512
MATERIAL	RUBBER COATED PLASTIC
LENGTH	173mm - 6.81"
WIDTH	115mm - 4.50"
HEIGHT	50mm - 1.96"
NETT WEIGHT	0.24kg - 0.53lb
TEMPERATURE RANGE	-50 to 800°C
D:S RATIO	12:1
ACCURACY	+1.5°C / +1.5%
RESOLUTION	0.1°C / 0.1°F
°C/°F ADJUSTABLE	YES
LASER POINTER	YES
LASER POWER	<1mW
BACKLIT DISPLAY	YES
DATA HOLD	YES
DATA STORAGE & RECALL	YES
MINIMUM MODE	YES
MAXIMUM MODE	YES
AVERAGE MODE	YES
DIFFERENCE MODE	YES
HIGH TEMPERATURE ALARM	YES
LOW TEMPERATURE ALARM	YES
AUTO POWER-OFF	30 SECONDS
LOW BATTERY INDICATOR	YES
EMISSIVITY	0.10 TO 1.00 ADJUSTABLE
OPERATING TEMPERATURE	0-40°C
OPERATING HUMIDITY	10-95% RH
STORAGE TEMPERATURE	-20 TO 60°C (WITHOUT BATTERY)
POWER SUPPLY	9V BATTERY (INCLUDED)



STEERING WHEEL QUICK RELEASES

Quick system
 Lenkradschnellverschluss
 Mozzo a sgancio rapido
 Extractor de volante

The B-G Quick Release systems allow for quick and easy removal of the steering wheel from the column, making it much easier to get in and out of any car.

The Bolt-On ball bearing systems feature a safety release button and are multi-drilled to suit 6x70mm & 6x74mm PCD steering wheels and hubs (BG4921) or 6x101 & 9x101.6mm PCD hubs (BG4924).

The Bolt-On 6x70mm PCD (BGR706) and Weld-On variants (BGR700 – BGR704) feature a master spline positioned dead centre which allows the use of the steering wheel as a reference point, ensuring perfect alignment every time.

20mm length steel splined shafts are available in a choice of 5/8" (16mm) or 3/4" (19mm) diameters that will require welding to the steering column.



TECHNICAL SPECIFICATIONS	
CLASSIC APPLICATIONS	
PART NUMBER	BGR4924
MATERIAL	ALUMINIUM
FINISH	ANODISED
TYPE	BOLT-ON
PCD HUB	6 x 101mm & 9 x 101.6mm to
PCD ST/WHL	6 x 70mm & 6 x 74mm
PCD HUB	6 x 3.98" & 9 x 4" to
PCD ST/WHL	6 x 2.75" & 6 x 2.91"
THICKNESS	60mm - 2.63"
WIDTH	123mm - 4.84"
NETT WEIGHT	680g - 1.49lb

TECHNICAL SPECIFICATIONS

MODERN APPLICATIONS

PART NUMBER	BGR4921
MATERIAL	ALUMINIUM
FINISH	ANODISED
TYPE	BOLT-ON
PCD	6 x 70mm & 6 x 74mm 6 x 2.75" & 6 x 2.91"
THICKNESS	60mm - 2.36"
WIDTH	123mm - 4.84"
NETT WEIGHT	620g - 1.37lb



TECHNICAL SPECIFICATIONS

PART NUMBER	BGR706
MATERIAL	ALUMINIUM & STEEL
FINISH	ANODISED
TYPE	BOLT-ON
PCD	6 x 70mm - 6 x 2.75"
THICKNESS	67mm - 2.64"
WIDTH	82mm - 3.22"
NETT WEIGHT	440g - 0.98lb



BGR703 / BGR704

BGR700 / BGR701

TECHNICAL SPECIFICATIONS

PART NUMBER	BGR700	BGR701
MATERIAL	ALUMINIUM & STEEL	ALUMINIUM & STEEL
FINISH	ANODISED & POWDER COATED	ANODISED & POWDER COATED
TYPE	WELD-ON	WELD-ON
PCD	3 x 50.8mm - 3 x 1.73"	3 x 50.8mm - 3 x 1.73"
THICKNESS	85mm - 3.35"	85mm - 3.35"
WIDTH	57mm - 2.24"	57mm - 2.24"
SHAFT SIZE	16mm - 5/8"	19mm - 3/4"
NETT WEIGHT	260g - 0.57lb	280g - 0.61lb

TECHNICAL SPECIFICATIONS

PART NUMBER	BGR703	BGR704
MATERIAL	ALUMINIUM & STEEL	ALUMINIUM & STEEL
FINISH	ANODISED & POWDER COATED	ANODISED & POWDER COATED
TYPE	WELD-ON	WELD-ON
PCD	6 x 70mm & 6.74mm 6 x 2.75" & 6 x 2.91"	6 x 70mm & 6.74mm 6 x 2.75" & 6 x 2.91"
THICKNESS	90mm - 3.54"	90mm - 3.54"
WIDTH	85mm - 3.35"	85mm - 3.35"
SHAFT SIZE	16mm - 5/8"	19mm - 3/4"
NETT WEIGHT	340g - 0.75lb	360g - 0.79lb



5/8" (16MM) SHAFT

3/4" (19MM) SHAFT

B-G Steering Wheel Carry Bag

Keep your steering wheel protected during storage and transportation when removed from the car.



TECHNICAL SPECIFICATIONS

PART NUMBER	BG5147
MATERIAL	NYLON
WIDTH	410mm - 16.14"
DEPTH	150mm - 0.59"

T: +44 (0) 1268 764411
 E: sales@bg-racing.co.uk
 W: www.bg-racing.co.uk



STEERING WHEEL SPACERS / ADAPTORS

Entretoise de volant
Aluminium-Lenkradverlängerung
Distanziale per volante
Distanciador de volante

A wide range of steering wheel spacers and adaptors to cater for a variety of applications. All spacers and adaptors are produced from aluminium with a black anodised finish and supplied with fixing screws.



TECHNICAL SPECIFICATIONS

MODERN HUB TO CLASSIC ST/WHL PCD ADAPTOR

PART NUMBER	BG4911
MATERIAL	ALUMINIUM
FINISH	BLACK ANODISED
PCD HUB	6 x 70mm & 6 x 74mm
PCD ST/WHL	6 x 101mm & 9 x 101.6mm
PCD HUB	6 x 2.75" & 6 x 2.91"
PCD ST/WHL	6 x 3.98" & 9 x 4"
THICKNESS	10mm - 0.39"
NETT WEIGHT	164g - 0.36lb



TECHNICAL SPECIFICATIONS

CLASSIC STEERING WHEEL SPACER

PART NUMBER	BG4927
MATERIAL	ALUMINIUM
FINISH	BLACK ANODISED
PCD ST/WHL	6 x 101mm & 9 x 101.6mm
	6 x 3.98" & 9 x 4"
THICKNESS	15mm - 0.59"
NETT WEIGHT	164g - 0.36lb



TECHNICAL SPECIFICATIONS

6 HOLE ECCENTRIC SPACER

PART NUMBER	BG4913
MATERIAL	ALUMINIUM
FINISH	BLACK ANODISED
PCD	6 x 70mm - 6 x 2.75"
OFFSET	10mm - 0.39"
THICKNESS	15mm - 0.59"
NETT WEIGHT	140g - 0.31lb



TECHNICAL SPECIFICATIONS

LOTUS OEM ECCENTRIC SPACER

PART NUMBER	BG4926
MATERIAL	ALUMINIUM
FINISH	BLACK ANODISED
PCD	4 x 77mm - 4 x 3.03"
OFFSET	15mm - 0.59"
THICKNESS	20mm - 0.78"
NETT WEIGHT	200g - 0.44lb



TECHNICAL SPECIFICATIONS 6 HOLE STEERING WHEEL SPACERS

PART NUMBER	BG4915	BG4916	BG4917	BG4923	BG4918	BG4919	BG4920
MATERIAL	ALUMINIUM	ALUMINIUM	ALUMINIUM	ALUMINIUM	ALUMINIUM	ALUMINIUM	ALUMINIUM
FINISH	BLACK ANODISED	BLACK ANODISED	BLACK ANODISED	BLACK ANODISED	BLACK ANODISED	BLACK ANODISED	BLACK ANODISED
PCD	6 x 70mm & 6 x 74mm	6 x 70mm & 6 x 74mm	6 x 70mm & 6 x 74mm	6 x 70mm & 6 x 74mm	6 x 70mm & 6 x 74mm	6 x 70mm & 6 x 74mm	6 x 70mm & 6 x 74mm
	6 x 2.75" & 6 x 2.91"	6 x 2.75" & 6 x 2.91"	6 x 2.75" & 6 x 2.91"	6 x 2.75" & 6 x 2.91"	6 x 2.75" & 6 x 2.91"	6 x 2.75" & 6 x 2.91"	6 x 2.75" & 6 x 2.91"
THICKNESS	10mm - 0.39"	20mm - 0.78"	40mm - 1.57"	60mm - 2.36"	80mm - 3.14"	100mm - 3.93"	120mm - 4.72"
NETT WEIGHT	100g - 0.22lb	160g - 0.35lb	200g - 0.44lb	220g - 0.49lb	260g - 0.57lb	320g - 0.71lb	360g - 0.79lb



T: +44 (0) 1268 764411
E: sales@bg-racing.co.uk
W: www.bg-racing.co.uk



TECHNICAL SPECIFICATIONS

6 HOLE PCD ST/WHL TO HUB ADAPTOR/SPACER

PART NUMBER	BG4914
MATERIAL	ALUMINIUM
FINISH	BLACK ANODISED
PCD	6 x 70mm – 6 x 74mm
	6 x 2.75" & 6 x 2.91"
THICKNESS	12.5mm – 0.49"
NETT WEIGHT	100g – 0.22lb



TECHNICAL SPECIFICATIONS

6 HOLE HUB TO 3 HOLE ST/WHL ADAPTOR

PART NUMBER	BG4912
MATERIAL	ALUMINIUM
FINISH	BLACK ANODISED
PCD	6 x 70mm TO 3 x 44.07mm & 3 x 50.8mm
	6 x 2.75" TO 3 x 1.73" & 3" x 2"
THICKNESS	12.5mm – 0.49"
NETT WEIGHT	230g – 0.51lb



TECHNICAL SPECIFICATIONS

ADJUSTABLE STEERING WHEEL SPACER

PART NUMBER	BG4922
MATERIAL	ALUMINIUM
FINISH	BLACK ANODISED
PCD	6 x 70mm – 6 x 74mm
	6 x 2.75" & 6 x 2.91"
ADJUSTMENT	45mm TO 70mm
	1.77" TO 2.75"
NETT WEIGHT	520g – 1.15lb



TECHNICAL SPECIFICATIONS

3 HOLE ECCENTRIC SPACER

PART NUMBER	BGR730
MATERIAL	ALUMINIUM
FINISH	BLACK ANODISED
PCD	3 x 50.8mm – 3 x 1.73"
OFFSET	10mm – 0.39"
THICKNESS	15mm – 0.59"
NETT WEIGHT	80g – 0.18lb



TECHNICAL SPECIFICATIONS

3 HOLE STEERING WHEEL SPACERS

PART NUMBER	BGR726	BGR727	BGR728	BGR729
MATERIAL	ALUMINIUM	ALUMINIUM	ALUMINIUM	ALUMINIUM
FINISH	BLACK ANODISED	BLACK ANODISED	BLACK ANODISED	BLACK ANODISED
PCD	3 x 50.8mm	3 x 50.8mm	3 x 50.8mm	3 x 50.8mm
	3 x 1.73"	3 x 1.73"	3 x 1.73"	3 x 1.73"
THICKNESS	12.7mm – 0.5"	25.4mm – 1.0"	38.1mm – 1.5"	50.8mm – 2.0"
NETT WEIGHT	40g – 0.09lb	80g – 0.18lb	120g – 0.27lb	160g – 0.35lb



TECHNICAL SPECIFICATIONS

3 HOLE HUB TO 6 HOLE STEERING WHEEL ADAPTOR

PART NUMBER	BGR725
MATERIAL	ALUMINIUM
FINISH	BLACK ANODISED
PCD	3 x 50.8mm – 3 x 1.73"
	6 x 70mm & 6 x 74mm
THICKNESS	6 x 2.75" & 6 x 2.91"
	12.7mm – 0.5"
NETT WEIGHT	100g – 0.22lb

B-G Hub Kits are produced in Italy from the finest cast aluminium materials and are dual drilled to be compatible with various steering wheels featuring either a 6 x 70mm PCD pattern (such as MOMO, Sparco, OMP, Simoni, Mountney M-Range, Italvolanti) or 6 x 74mm PCD pattern (such as Nardi, Personal, Raid). All B-G Hub Kits are supplied with fixing screws, allen key, and horn button retaining ring. Over 800 vehicle applications available.

TECHNICAL SPECIFICATIONS

PART NUMBER	BG8xxx
MATERIAL	ALUMINIUM
PCD	6 x 70mm & 6 x 74mm
	6 x 2.75" & 6 x 2.91"





WIDE ANGLE REAR VIEW MIRRORS

Rétroviseur intérieur
Weitwinkel Innenspiegel
Specchio retrovisore
Espejo Gran angular



These universal mirrors are perfect for the track. Featuring a convex glass to provide a wide field of view, they give you the best view of what's behind you.

Simply fasten the mirror to your roll cage using the bolt on brackets for a secure fitment that will not vibrate loose. All brackets are slotted to provide a wide range of adjustment and are secured to the mirror using wing knobs that allow for simple adjustment by hand.

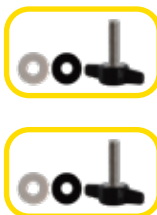

Available in either 15" or 17" mirror lengths with brackets to suit 1.5", 1.7", 1.75" or 2" diameter roll cage bars. 1.5" and 1.7" options are supplied with a set of Rubber Packers (BGR754) that fit inside the 1.75" brackets to reduce the diameter.



Individual components can be purchased separately or as part of a complete kit.



15" MIRRORS & KITS

PART NUMBER	BGR750	BGR755	BGR756	BGR757
MATERIAL	GLASS, ALUMINIUM & ABS PLASTIC	GLASS, ALUMINIUM & ABS PLASTIC	GLASS, ALUMINIUM, ABS PLASTIC & RUBBER	GLASS, ALUMINIUM & ABS PLASTIC
LENGTH (L)	381mm - 15.00"	381mm - 15.00"	381mm - 15.00"	381mm - 15.00"
HEIGHT (H)	66mm - 2.60"	66mm - 2.60"	66mm - 2.60"	66mm - 2.60"
WIDTH (W)	63mm - 2.48"	63mm - 2.48"	63mm - 2.48"	63mm - 2.48"
BRACKETS INCLUDED	NO	YES	YES	YES
ROLL CAGE BAR Ø	N/A	44.5mm - 1.75"	38.1mm - 1.50", 43.2mm - 1.70" & 44.5mm - 1.75"	50.8mm - 2.00"
PACKERS INCLUDED	NO	NO	YES	NO
NETT WEIGHT	280g - 0.62lb	380g - 0.84lb	400g - 0.88lb	400g - 0.88lb

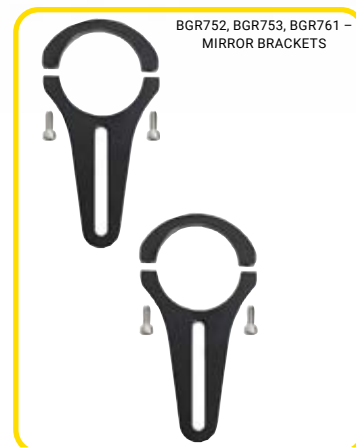

17" MIRRORS & KITS

PART NUMBER	BGR751	BGR758	BGR759	BGR760
MATERIAL	GLASS, ALUMINIUM & ABS PLASTIC	GLASS, ALUMINIUM & ABS PLASTIC	GLASS, ALUMINIUM, ABS PLASTIC & RUBBER	GLASS, ALUMINIUM & ABS PLASTIC
LENGTH (L)	432mm – 17.00"	432mm – 17.00"	432mm – 17.00"	432mm – 17.00"
HEIGHT (H)	80mm – 3.15"	80mm – 3.15"	80mm – 3.15"	80mm – 3.15"
WIDTH (W)	76mm – 2.99"	76mm – 2.99"	76mm – 2.99"	76mm – 2.99"
BRACKETS INCLUDED	NO	YES	YES	YES
ROLL CAGE BAR Ø	N/A	44.5mm – 1.75"	38.1mm – 1.50", 43.2mm – 1.70" & 44.5mm – 1.75"	50.8mm – 2.00"
PACKERS INCLUDED	NO	NO	YES	NO
NETT WEIGHT	380g – 0.84lb	480g – 1.06lb	500g – 1.10lb	500g – 1.10lb

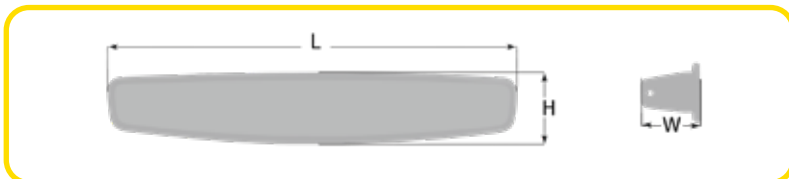

BRACKETS & PACKERS

PART NUMBER	BGR752	BGR753	BGR754	BGR761
MATERIAL	ALUMINIUM	ALUMINIUM	RUBBER	ALUMINIUM & RUBBER
ROLL CAGE BAR Ø	44.5mm – 1.75"	50.8mm – 2.00"	N/A	38.1mm – 1.50", 43.2mm – 1.70" & 44.5mm – 1.75"
PACKERS INCLUDED	NO	NO	YES	YES
NETT WEIGHT	100g – 0.22lb	120g – 0.27lb	23g – 0.05lb	120g – 0.27lb

Designed to solve the problem of where to store your removable steering wheel instead of putting it on the dashboard or passenger floor, the Steering Wheel Hook clamps directly to your roll cage.

CNC Machined from lightweight billet aluminium with a black anodised finish, the hook provides a secure fitment that will not vibrate loose thanks to the 2 bolts provided.

The hook is supplied with rubber inserts to make it suitable for 3 different diameter roll cage bars: 1.5" (38.1mm), 1.7" (43.2mm) or 1.75" (44.5mm).

The Hook could also be used for somewhere to hang your helmet or intercom headset when not in use.

TECHNICAL SPECIFICATIONS

PART NUMBER	BGR731
MATERIAL	ALUMINIUM
HEIGHT	128mm – 5.03"
WIDTH	10mm – 0.39"
DEPTH	63mm – 2.48"
ROLL CAGE BAR Ø	1.5", 1.7" or 1.75"
NETT WEIGHT	0.06kg – 0.13lb



T: +44 (0) 1268 764411
 E: sales@bg-racing.co.uk
 W: www.bg-racing.co.uk





ACCESSORIES

Accessoires
Zubehör
Accessori
Accesorios



PAPER TOWEL ROLL

PART NUMBER	BGR277
MATERIAL	PAPER 3PLY
COLOUR	BLUE
LENGTH	1000 SHEETS
PACK QUANTITY	1
SUITABLE FOR	BGR109P



PAPER TOWEL ROLLS

PART NUMBER	BGR278
MATERIAL	PAPER 2PLY
COLOUR	BLUE
LENGTH	400 SHEETS
PACK QUANTITY	6
SUITABLE FOR	BGR109P, BG6050P, BG6051P, BG6052P



ADJUSTABLE TORQUE WRENCH SET

PART NUMBER	BG5149
MATERIAL	STEEL
LENGTH	460mm - 18.11"
SOCKET SET	17mm, 19mm, 21mm & 5" EXTENSION
TORQUE RANGE	28Nm TO 210Nm - 2.9m-kg TO 21.4m-kg
NETT WEIGHT	1.86kg - 4.10lb



EURO BIN

PART NUMBER	BGR276EB	BGR275EB
MATERIAL	PLASTIC	PLASTIC
HEIGHT	120mm - 4.72"	120mm - 4.72"
WIDTH	300mm - 11.81"	400mm - 15.74"
LENGTH	400mm - 15.74"	600mm - 23.62"
SUITABLE FOR	BGR106P, BGR108P, BGR109P, BGR175P, BGR178, BGR179P	BGR106P, BGR108P

SPARE WHEEL SETS (INC. CARRIERS)

PART NUMBER	BGR118	BGR120	BGR120STD	BGR120SWI
WHEEL DIAMETER	160mm - 6.29"	160mm - 6.29"	160mm - 6.29"	160mm - 6.29"
WHEEL MATERIAL	ALUMINIUM CENTRE	ALUMINIUM CENTRE	POLYPROPYLENE	POLYPROPYLENE
TYRE MATERIAL	RUBBER	RUBBER	RUBBER	RUBBER
CARRIERS	2 x FIXED, 2 x SWIVEL & BRAKE	2 x FIXED, 2 x SWIVEL & BRAKE	2 x FIXED, 2 x SWIVEL & BRAKE	2 x SWIVEL, 2 x SWIVEL & BRAKE
SUITABLE FOR	BGR102S, BGR102SL	BGR108P, BGR108PAL, BGR110P, BGR111P,	BGR108P, BGR108PAL, BGR110P, BGR111P,	BGR108P, BGR108PAL, BGR110P, BGR111P,
	BGR103S, BGR103SL, BGR104S,	BGR113P, BGR114P, BGR123P, BGR124P,	BGR113P, BGR114P, BGR123P, BGR124P,	BGR113P, BGR114P, BGR123P, BGR124P,
	BGR104SL, BGR115S, BGR115SL	BGR190P, BGR191P, BGR192P	BGR190P, BGR191P, BGR192P	BGR190P, BGR191P, BGR192P

ACCESSORIES

Accessoires
Zubehör
Accessori
Accesorios



M12 ROD END

PART NUMBER	BGR121
MATERIAL	STEEL
SUITABLE FOR	BGR105S, BGR106P, BGR107P, BGR108PAF, BGR112P, BGR122P



TAPES

PART NUMBER	BGR308TAPES
LENGTH	5m / 16.4ft
COLOUR	YELLOW & BLACK
SUITABLE FOR	BGR308



STRING LINE REELS

PART NUMBER	BGR201
MATERIAL	PLASTIC
COLOUR	YELLOW & BLACK
SUITABLE FOR	BGR200



LEVELLING FEET

PART NUMBER	BGR357
MATERIAL	STEEL
FINISH	ZINC PLATED
PACK QUANTITY	4
SUITABLE FOR	BGR351, BGR352, BGR353, BGR129, BGR130



LEVELLING FOOT EXTENSION KIT

PART NUMBER	BGR356
MATERIAL	POLYOXYMETHYLENE
COLOUR	BLACK
PACK QUANTITY	4
SUITABLE FOR	BGR351, BGR352, BGR353

LAP TIMING SHEET

DATE: _____ TRACK: _____ WEATHER: _____
 REGION: _____ TRACK LENGTH: _____ FUEL TYPE: _____
 SERIAL: _____ TRACK TEMP: _____ FUEL LOAD: _____
 CAR: _____ IP: _____ AMBIENT TEMP: _____ CONSUMPTION: _____

LAP NO.	TIME	NOTES & ADJUSTMENTS
1		
2		
3		
4		
5		
6		
7		
8		
9		
10		
11		
12		
13		
14		
15		
16		
17		
18		
19		
20		
21		
22		
23		
24		
25		
26		
27		
28		
29		
30		

COMMENTS: _____

SET UP SHEET

DATE: _____ TRACK: _____ WEATHER: _____
 SERIAL: _____ CAR: _____ IP: _____
 LEFT FRONT (LF) _____ RIGHT FRONT (RF) _____

WEIGHT	CAMBER	TOE	RIDE HEIGHT	SPRING RATE	DAMPER SETTING SLIP	DAMPER SETTING RESOARD	SET UP TIRE PRESSURE	TIRE SIZE / ALTERNATIVE
LF								
RF								
LR								
RR								

LF & RR: _____ CROSS WEIGHTS _____ SF & LR: _____
 FRONT: _____ BRAKE BALANCE _____ REAR: _____
 FRONT: _____ ROLL BAR _____ REAR: _____
 DAMPER WEIGHT: _____
 SHOCK: _____
 BALLJETS: _____
 FRONT: _____ TOTAL WEIGHT: _____ REAR: _____
 LEFT: _____ RIGHT: _____

COMMENTS: _____



LAP TIMING & CHASSIS SET UP SHEETS

PART NUMBER	BGR425	BGR426
MATERIAL	A4 PAPER	A4 PAPER
SHEETS	50	50
HOLE PUNCHED	4 HOLE PUNCHED	4 HOLE PUNCHED
GLUED SIDE	TOP EDGE	TOP EDGE

50 YEARS OF ESCORT T-SHIRT

PART NUMBER	BGRTSHIRT50
MATERIAL	COTTON & POLYESTER
COLOUR	GREY
SIZE	S, M, L, XL, 2XL, 3XL, 4XL, 5XL

T: +44 (0) 1268 764411
 E: sales@bg-racing.co.uk
 W: www.bg-racing.co.uk



ACCESSORIES



DIGITAL CALIPER - 100mm

PART NUMBER	BG5153
MATERIAL	CARBON FIBRE COMPOSITE
WIDTH	80mm - 3.15"
LENGTH	225mm - 8.85"
MEASURING RANGE	0 to 100mm - 0 to 4"
RESOLUTION	0.1mm - 0.01"



DIGITAL CALIPER - 150mm

PART NUMBER	BG5154
MATERIAL	STAINLESS STEEL
WIDTH	95mm - 3.74"
LENGTH	240mm - 9.45"
MEASURING RANGE	0 to 150mm - 0 to 6"
RESOLUTION	0.01mm - 0.001"



DIGITAL TREAD DEPTH GAUGE

PART NUMBER	BG5152
MATERIAL	STEEL AND PLASTIC
WIDTH	75mm - 3.00"
LENGTH	155mm - 6.10"
MEASURING RANGE	0 to 25.4mm - 0 to 1"
RESOLUTION	0.01mm - 0.001"



LIGHTWEIGHT TOOL TRAY

PART NUMBER	BGR181P
MATERIAL	MILD STEEL
HEIGHT	120mm - 4.72"
WIDTH	190mm - 7.48"
LENGTH	375mm - 14.76"
NETT WEIGHT	1.50kg - 3.31lb



ENGINE CARRY STANDS (PAIR)

PART NUMBER	BG5134
MATERIAL	MILD STEEL
FINISH	BLACK POWDER COATED
NETT WEIGHT	5.2kg - 11.46lb
SUITABLE FOR	FORD PINTO, PRE X-FLOW, X-FLOW, LOTUS TWIN CAM, BDA, BDG



ENGINE CARRY STANDS (PAIR)

PART NUMBER	BG5137
MATERIAL	MILD STEEL
FINISH	BLACK POWDER COATED
NETT WEIGHT	5.1kg - 11.24lb
SUITABLE FOR	FORD DURATEC

LIKE WHAT YOU SEE?

Come and join the B-G family!
The B-G Racing website is the central hub to view all of the latest products, 360 degree imagery, technical specifications, videos and news.

WWW.BG-RACING.CO.UK

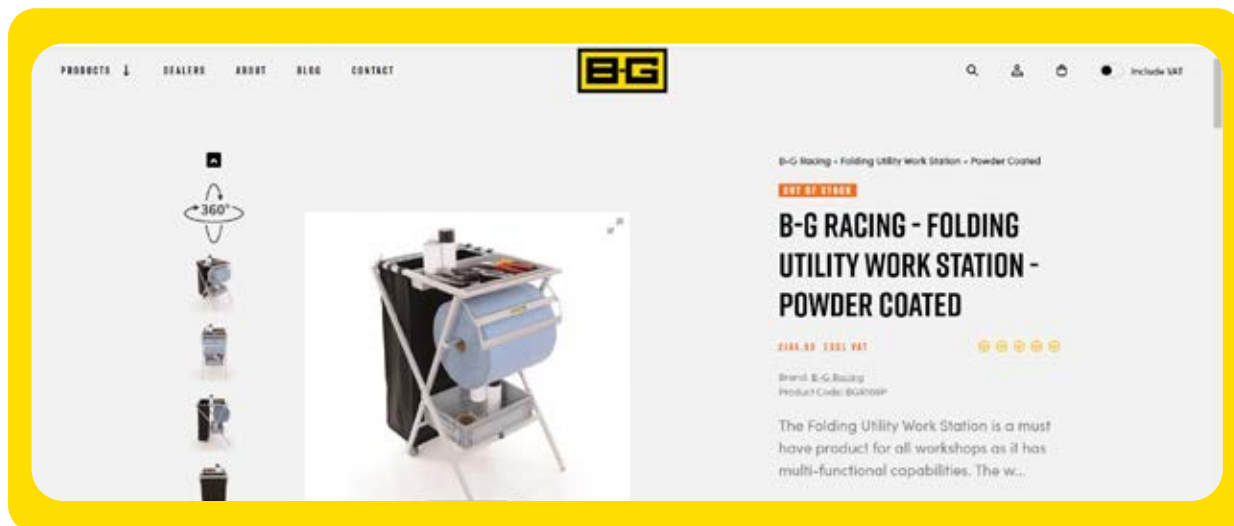

LET'S GET SOCIAL!

You can also find us on Facebook, Twitter, Instagram and Youtube where you can keep updated on racing events, shows, products and life in the B-G office!



@brownandgeeson



@BG_Racing



Brown Geeson



@brown_and_geeson

T: +44 (0) 1268 764411
E: sales@bg-racing.co.uk
W: www.bg-racing.co.uk





Racing

MOTORSPORT EQUIPMENT

BROWN AND GEESON LTD
12 Buckingham Square,
Wickford Business Park,
Wickford, Essex
SS11 8YQ
United Kingdom

Tel: +44 (0) 1268 764411
Email: sales@bg-racing.co.uk
Web: www.bg-racing.co.uk

DISTRIBUTED BY:

